

**STANDARD CONSTRUCTION SPECIFICATIONS FOR
PORTLAND CEMENT CONCRETE
DIVISION 30
I N D E X**

SECTION 30.01	GENERAL.....	1
Article 1.1	Scope of Work.....	1
Article 1.2	Applicable Standards	1
Article 1.3	Materials	2
Article 1.4	Mix	5
Article 1.5	Subbase.....	6
Article 1.6	Mix Requirements for Classes of Concrete.....	6
Article 1.7	Ready-Mixed Concrete	8
Article 1.8	Sampling and Testing	9
Article 1.9	Weather Limitations	9
Article 1.10	Protection of Work.....	9
Article 1.11	Clean-up	10
SECTION 30.02	PORTLAND CEMENT CONCRETE, CURB AND GUTTER AND VALLEY GUTTER	11
Article 2.1	Description	11
Article 2.2	Materials	11
Article 2.3	Construction	12
Article 2.4	Measurement	16
Article 2.5	Basis of Payment	16
SECTION 30.03	PORTLAND CEMENT CONCRETE SIDEWALKS.....	17
Article 3.1	Description	17
Article 3.2	Materials	17
Article 3.3	Construction	17
Article 3.4	Measurement	19
Article 3.5	Basis of Payment	20
SECTION 30.04	PORTLAND CEMENT CONCRETE CURB RAMPS.....	21
Article 4.1	General	21
Article 4.2	Materials	21
Article 4.3	Construction	22
Article 4.4	Tolerances	23
Article 4.5	Measurement	23
Article 4.6	Basis of Payment	24
SECTION 30.05	STRUCTURES AND RETAINING WALLS	25
Article 5.1	Description	25
Article 5.2	Construction	25
Article 5.3	Measurement	28
Article 5.4	Basis of Payment	29

SECTION 30.06	CONCRETE MASONRY RETAINING WALLS	30
Article 6.1	Description	30
Article 6.2	Construction	30
Article 6.3	Measurement	32
Article 6.4	Basis of Payment	32
SECTION 30.07	CONCRETE – BUILDING STRUCTURES.....	33
Article 7.1	Description	33
Article 7.2	Materials	33
Article 7.3	Formwork Construction	33
Article 7.4	Concrete	35
Article 7.5	Measurement	37
Article 7.6	Basis of Payment	37
SECTION 30.08	PORTLAND CEMENT CONCRETE CLUSTER MAILBOX BASE	38
Article 8.1	General	38
Article 8.2	Materials and Installation	38
Article 8.3	Construction	38
Article 8.4	Measurement	38
Article 8.5	Basis of Payment	38
SECTION 30.09	CONCRETE PARKING BUMPERS	39
Article 9.1	Description	39
Article 9.2	Material	39
Article 9.3	Construction	39
Article 9.4	Basis of Payment	39
SECTION 30.10	IMPRINTED COLORED CONCRETE.....	40
Article 10.1	General	40
Article 10.2	Materials	40
Article 10.3	Construction	40
Article 10.4	Measurement	41
Article 10.5	Basis of Payment	41
SECTION 30.11	SIDEWALK JOINT SEALANT	42
Article 11.1	General	42
Article 11.2	Materials	42
Article 11.3	Construction	42
Article 11.4	Measurement	42
Article 11.5	Basis of Payment	42

**STANDARD CONSTRUCTION SPECIFICATIONS FOR
PORTLAND CEMENT CONCRETE
DIVISION 30**

SECTION 30.01 GENERAL

Article 1.1 Scope of Work

The Work covered by this Section consists of providing all plant, labor, equipment, supplies, material, transportation, handling, storage and protection for performing all operations in connection with the placement of Portland Cement Concrete in accordance with the Specifications and the Drawings.

Article 1.2 Applicable Standards

The latest revision of the following standards of the American Society for Testing and Materials (ASTM) and American Society of State Highway and Transportation Officials (AASHTO) are hereby made a part of these Specifications:

American Concrete Institute		"Manual of Concrete Practice"
Concrete Reinforcing Steel Institute		"Manual of Standard Practice"
ASTM A-185	AASHTO M-55	Specification for Welded Steel Wire Fabric for Concrete
ASTM A-615	AASHTO M-31	Specification for Billet-Steel Bars for Concrete Reinforcement
ASTM C-31	AASHTO T-23	Method of Making and Curing Concrete Compression and Flexure Test Specimens in the Field
ASTM C-33		Specification for Concrete Aggregates
ASTM C-330		Specification for Lightweight Aggregates for Structural Concrete
ASTM C-39	AASHTO T-22	Test for Compressive Strength of Molded Concrete Cylinders.
ASTM C-40	AASHTO T-21	Test for Organic Impurities in Sands for Concrete
ASTM C-42	AASHTO T-24	Method of Securing, Preparing and Testing Specimens from Hardened Concrete for Compression and Flexure Strengths
ASTM C-90		Hollow Load-Bearing Concrete Masonry

ASTM C-94	AASHTO M-157	Specification for Ready-Mix Concrete
ASTM C-150	AASHTO T-119	Specification for Portland Cement
ASTM C-156	AASHTO T-155	Test for Water Retention Efficiency of Liquid Membrane-Forming Compounds and Impermeable Sheet Materials for Curing Concrete.
ASTM C-171	AASHTO M-171	Specification for Waterproof Paper for Curing Concrete
ASTM C-172	AASHTO T-141	Sampling Fresh Concrete
ASTM C-192	AASHTO T-126	Method of Making and Curing Concrete Compression and Flexure Test Specimens in the Laboratory
ASTM C-226	AASHTO M-134	Specification for Air-Entraining Additions for Use in the Manufacture of Air-Entraining Portland Cement
ASTM C-231	AASHTO T-152	Test for Air Content of Freshly Mixed Concrete by the Pressure Method
ASTM C-260	AASHTO M-154	Specification for Air-Entraining Admixture for Concrete
ASTM C-270		Mortar for Unit Masonry (Including Tentative Revision)
ASTM C-309	AASHTO M-148	Specification for Liquid Membrane-Forming Compounds for Curing Concrete
ASTM C-494	AASHTO M-194	Specifications for Chemical Admixtures for Concrete
ASTM D-1751	AASHTO M-213	Specification for Preformed Expansion Joint Filler for Concrete Paving and Structural Construction (Nonextruding and Resilient Bituminous Types)
AASHTO M-6		Specification for Fine Aggregate for Portland Cement Concrete
AASHTO M-32		Specification for Cold Drawn Steel Wire for Concrete Reinforcement Cement
AASHTO M-80		Specification for Coarse Aggregate for Portland Concrete

Article 1.3 Materials

A. Reinforcing Steel

Concrete reinforcing shall be deformed steel bars conforming to the requirements of ASTM A-615 (AASHTO M-31). It shall be free from loose scales, excessive rust,

and coatings of any character which will reduce the bond between steel and concrete.

If reinforcing bars are to be welded, these Specifications shall be supplemented by requirements assuring satisfactory weldability in conformity with AWS D12.1, "Recommended Practices for Welding Reinforcing Steel, Metal Inserts and Connections in Reinforced Concrete Construction."

B. Welded Steel Wire Fabric

The welded steel wire fabric shall be cold-drawn steel wires or galvanized, fabricated into mesh formed by the process of electric welding. The grade of wire shall conform to AASHTO M-32. Welded Steel Wire Fabric shall conform to ASTM A-185 (AASHTO M-55).

C. Cement

The cement shall be of a recognized standard brand of Portland Cement conforming to the specification requirements listed below and of a type listed below:

<u>Specification</u>	<u>Type Portland Cement</u>
ASTM C-150	Type I, III*
AASHTO M-85	Type I, III*

*Type III cement may be used upon written authorization of the Engineer subject to the following modification:

Minimum design strength shall be achieved in seven (7) days in lieu of the twenty-eight (28) days required for Type I cement.

For architectural concrete only one brand of cement shall be used unless otherwise approved by the Engineer. When no type cement is specified, the requirements of Type I shall govern.

Cement reclaimed from cleaning bags or leaking containers shall not be used.

The Engineer may require an additional one-half sack of Portland concrete over the design specification.

D. Water

Water used for the mixing of concrete shall be clean and free of oil or acid, and shall not contain salt, alkali, or organic matter.

E. Aggregates

Aggregates for Portland Cement Concrete shall be well graded, clean, hard gravel, and coarse sand, non-frost susceptible material, and free of deleterious (organic)

matter, and coatings of silt or clay. The gradations shall be determined by standard laboratory sieves with square openings. Material retained on a No. 4 screen shall be classified as coarse aggregate, which shall conform to the requirements of AASHTO M-80 and have the following limits of gradation:

Coarse Aggregate for Portland Cement Concrete

U.S. Standard Sieve Size	AASHTO No. 67 ($\frac{3}{4}$ " to #4)	AASHTO No. 4 (1 $\frac{1}{2}$ " to $\frac{3}{4}$ ")
	Cumulative <u>% Passing By Weight</u>	Cumulative <u>% Passing By Weight</u>
2"	-----	100
1 $\frac{1}{2}$ "	-----	90-100
1"	100	20-55
$\frac{3}{4}$ "	90-100	0-15
$\frac{1}{2}$ "	-----	-----
$\frac{3}{8}$ "	20-55	0-5
#4	0-10	-----
#8	0-5	-----

All material passing a No. 4 sieve shall be classified as fine aggregate and shall conform to the requirements of AASHTO M-6 and have the following gradation:

Fine Aggregate for Portland Cement Concrete

U.S. Standard <u>Sieve Size</u>	Cumulative <u>% Passing By Weight</u>
$\frac{3}{8}$ "	100
#4	95-100
#8	80-100
#16	50-85
#30	25-60
#50	10-30
#100	2-10

Aggregates shall consist of washed sand gravel; fine and coarse aggregates shall be regarded as separate ingredients. Aggregates for normal weight concrete shall conform to the requirements of ASTM C-33 and aggregates for light weight concrete, shall conform to the requirements of ASTM C-330.

The maximum size of coarse aggregates shall not exceed one and one-half inches (1 1/2") nor one-fifth (1/5) of the narrowest dimension between the forms nor three-quarters (3/4) of the clear spacing between reinforcing bars nor one-third (1/3) of the depth of slabs. The combined aggregates, coarse and fine, shall be of such composition of sizes that when separated on the No. 4 standard sieve, the weight passing shall not be less than thirty percent (30%) nor greater than fifty percent (50%) of the total weight.

The volume removed by sedimentation shall not exceed three percent (3%). Proportioning of the coarse and fine aggregate shall be obtained by weight. The weighing equipment shall be accurate within one percent (1%) of the net weight of the batch and shall permit adjustment for variations in the water content of the aggregate. Batching for fractional sacks of cement will not be permitted unless the cement is weighed for each batch. The water added shall be measured by an approved calibrated device capable of metering within one percent (1%) of the total amount of water to be used for each batch.

F. Air-Entrainment

Air-entrainment agents shall be used in all concrete. Entrainment shall be achieved by the addition of an approved air-entraining mixture to the concrete mix. Air-entrainment shall conform to ASTM C-231 (AASHTO T-152). Refer to Article 1.6 - Mix Requirements for Classes of Concrete for air-entrainment percentages for each class of concrete.

G. Curing Materials

Curing materials shall be one the following types as approved by the Engineer:

1. Kraft paper conforming to the requirements of ASTM C-171 (AASHTO M-171).
2. Mats of commercial quality and of a type used for curing concrete.
3. Burlap of commercial quality weighing not less than fourteen (14) ounces per square yard.
4. Membrane curing compound conforming to the requirements of ASTM C-309 (AASHTO M-148).

H. Expansion Joints

Premolded joint filler for use in expansion joints shall conform to the requirements of ASTM D-1751 (AASHTO M-213).

Article 1.4 Mix

Portland Cement Concrete may be mixed at a central mixing plant or in transit mixers. All mixing equipment and operations shall conform to the requirements of ASTM C-94

(AASHTO M-157). All concrete shall be delivered to the work site thoroughly mixed to a uniform color and show uniform distribution of aggregates and cement throughout the mixture.

Concrete shall be delivered to the Project site, discharged from the truck completely and in the forms ready for vibration within one and one-half (1-1/2) hours after introduction of the cement to the aggregates. At the discretion of the Engineer, the above period may be extended one (1) minute for every degree of temperature at which the concrete is delivered below seventy degrees (70°) Fahrenheit to a maximum total time of two (2) hours.

In hot weather, or under conditions contributing to quick setting of the concrete, a discharge time less than one and one-half (1-1/2) hours may be required by the Engineer. Any concrete remaining undischarged at the end of the respective time period shall be rejected.

The use of non-agitating equipment for transporting concrete will not be permitted. The mixing drums of transit-mix trucks shall be thoroughly washed after discharging each load to prevent the accumulation of adherent layers of concrete. The discharge of particles of hardened concrete with any batch will be sufficient grounds for the rejection of the entire batch. On curb, gutter and sidewalk work, transit mix trucks shall be operated parallel to the forms while discharging.

The addition of water to the mix at the job site will not be permitted except with the approval of the Engineer. Any additional water that is added shall be documented and recorded on the delivery ticket by a representative of the supplier.

Article 1.5 Subbase

Prior to placement of forms, the Engineer shall inspect the subbase to insure that it is smooth, compacted and free of soft or yielding spots and that compaction at optimum moisture is at least ninety-five percent (95%) of maximum density (AASHTO T-180 D). Backfilling within the forms will be permitted if the subbase is brought to the above specification and care is taken to maintain the forms to line, shape elevation.

Article 1.6 Mix Requirements for Classes of Concrete

The minimum mix requirement for classes of concrete shall be as set forth below, unless otherwise specified in the Contract Documents.

CLASS OF CONCRETE

	<u>C-6</u>	<u>B-3</u>	<u>B-6</u>	<u>A-3</u>	<u>A-6</u>	<u>AA-3</u>	<u>AA-6</u>
Minimum Cement Content in Sacks/Cu. Yd.	4.5	5.0	5.0	5.5	5.5	6.0	6.0
Maximum Water Content Ratio in Gal./Sack	6.5	6.5	6.5	6.5	6.5	5.75	5.5
Slump Ranges in Inches	1-5	2-4	1-3.5	2-4	1-3.5	2-4	1-2
Entrained Air Range in Percentage	3-6	4-7	3-6	4-7	3-6	4-7	3-6
Coarse Aggregate (AASHTO Gradation)	No.4 and No. 67	No. 67	No. 4* and No. 67	No. 67	No. 4* and No. 67	No. 67	No. 4* and No. 67
Fine Aggregate Shall Conform to AASHTO M-6 Gradation							
Minimum Design Strength (fc), psi	2000	2500	2500	3000	3000	3500	3500

Minimum design compressive strength specification shall be achieved in twenty-eight (28) days.

*The coarse aggregate for Class B-6, A-6, and AA-6 concrete shall be furnished in two (2) separate sizes.

Alternate mix designs will be considered upon submitting to the Engineer the following information:

1. MOA mix design designation for which the substitution is intended.
2. Design strength.
3. Air content.
4. Slump.
5. Aggregate gradation and maximum size.
6. Maximum water/cement ratio.
7. Minimum cement content.
8. List of admixtures, strength overdesign, and other special features.
9. Fine aggregate weight/percent moisture of fine aggregate.
10. Intermediate aggregate weight/percent moisture of intermediate aggregate.

11. Coarse aggregate weight/percent moisture of coarse aggregate.
12. Weight of cement.
13. Weight of water.
14. Unit weight.

Water shall not be used to increase slump beyond four inches (4"). If additional slump is desired, a plasticizing agent may be used subject to the Engineer's written approval.

Article 1.7 Ready-Mixed Concrete

Ready-mixed concrete shall conform to the requirements of ASTM C-94 (AASHTO M-157). For each batch of concrete, it is the responsibility of the Contractor to furnish to the Engineer, before unloading at the site, a delivery ticket from the manufacturer on which is printed, stamped or written, information concerning said concrete as follows:

1. Name of ready-mix batch plant.
2. Serial number of ticket.
3. Date and truck number.
4. Name of Contractor.
5. Specific designation of Project (name and location).
6. Specific class of concrete in conformance with that employed in Specifications.
7. Amount of concrete (cubic yards).
8. Time loaded or first mixing of cement and aggregate.
9. Type of cement.
10. Admixtures and amount of same.
11. Slump requested by the Contractor and recorded in inches.
12. Percentage of entrained air requested by the Contractor.
13. Fine aggregate weight/percent moisture of fine aggregate.
14. Intermediate aggregate weight/percent moisture of intermediate aggregate.
15. Coarse aggregate weight/percent moisture of coarse aggregate.
16. Weight of cement.
17. Weight of water.
18. Unit weight.

Article 1.8 Sampling and Testing

The Engineer shall take concrete samples for concrete cylinders in accordance with AASHTO T-141. Samples shall not be taken at the beginning or end of discharge. Making and curing the specimens shall be done in accordance with AASHTO T-23. Testing and sampling shall be done by the Engineer.

Slump tests shall be taken in accordance with AASHTO T-119 or ASTM C-143. Slump tests shall be taken by the Engineer.

Should the analysis of any test cylinder not meet the requirements of these Specifications, all concrete placed from the batch represented by the cylinder shall be removed and replaced at the Contractor's expense.

Article 1.9 Weather Limitations

Placement of Portland Cement Concrete is subject to the following requirements:

1. Salt, chemicals, or other material shall not be mixed with the concrete to prevent freezing.
2. Placement of concrete shall be prohibited whenever there is standing water on the grade or in the forms, the subgrade is yielding due to saturation, or rain is threatening.
3. Approved admixture shall be used in accordance with the manufacturer's recommendations.

Placement of concrete shall be prohibited at an ambient air temperature of less than forty degrees (40°) Fahrenheit or where the foundation material is frozen, except in special situations where authorized by the Engineer in writing. Exemption from the temperature clause of these Specifications shall be considered only under the following conditions:

A written proposal shall be submitted by the Contractor to the Engineer outlining a procedure for maintaining the placed concrete temperature of at least fifty degrees (50°) Fahrenheit for seventy-two (72) hours where Type III cement has been used and one hundred and twenty (120) hours where Type I cement has been used. When the temperature is reduced, the drop in temperature must be gradual and not exceed thirty degrees (30°) Fahrenheit in the first twenty-four (24) hours.

Article 1.10 Protection of Work

The Contractor shall protect all newly placed concrete from damage of any kind to prevent disfigurement during the curing period. Damaged concrete shall be repaired or replaced to the Engineer's satisfaction at no additional cost.

Type I/II Portland Cement Concrete must have been placed and finished a minimum of seven (7) days prior to material being distributed against, or vibrated (compaction) adjacent to the structure.

Type III Portland Cement Concrete must have been placed and finished a minimum of three (3) days prior to material being distributed against, or vibrated (compaction) adjacent to the structure.

Article 1.11 Clean-up

When all concrete Work has been completed and cured, the Contractor shall remove the forms, stakes, blocking, and concrete spoil from the site. The area adjoining the concrete that was excavated to permit the construction and placement of forms shall be filled with select material, and the slopes and parking areas, if any, shall be filled, shaped and smoothed to the level as shown on the Drawings or Standard Details.

SECTION 30.02 PORTLAND CEMENT CONCRETE, CURB AND GUTTER AND VALLEY GUTTER

Article 2.1 Description

The Work covered under this Section consists of the construction of curbs, gutters, miscellaneous median shapes and parking stops.

Article 2.2 Materials

Portland Cement Concrete, joint filler, reinforcing steel and curing materials shall conform to Section 30.01, Article 1.3 - Materials. Concrete mix for curbs shall conform to the requirements for Class A-3 unless otherwise specified.

A. Reinforcing Steel and Steel Dowels

Refer to Section 30.01, Article 1.3, SubArticle A. - Reinforcing Steel and SubArticle B. - Welded Steel Wire Fabric.

B. Prefomed Expansion and Dummy Joint Filler

Refer to Section 30.01, Article 1.3, SubArticle H. - Expansion Joints.

C. Curing Compounds

Refer to Section 30.01, Article 1.3, SubArticle G. – Curing Materials.

D. Forms

Forms may be of wood or metal or any other material at the option of the Contractor, provided that the forms as set will result in a curb, or curb and gutter of the specified thickness, cross section, grade and alignment shown on the Drawings.

Forms may be removed on the day following pour if the concrete is sufficiently set that removal can be accomplished without danger of chipping or spalling. Form materials shall be free from warp, with smooth and straight upper edges, and if used for the face of a curb, shall be surfaced on the side against which the concrete is to be placed. Wooden forms for straight work shall have a net thickness of at least one and one-half inches (1.5"). Metal forms for such a work shall be of a gage that will provide equivalent rigidity and strength. Curb face forms used on monolithic curb and gutter construction shall be a single plank width when the curb face is ten inches (10") or less, except for those used in curb returns. All forms used in curb returns shall not be less than three-quarters inches (3/4") in thickness, cut in the length and radius as shown on the Drawings, and held rigidly in place to line and grade by the use of metal stakes and clamps. The curb face form shall be cut to conform exactly with the curb face batter as well as being cut to the required length and radius. Forms shall be of sufficient rigidity and strength, and shall be

supported to adequately resist springing or deflection from placing and tamping of concrete.

Form material shall be clean and free from defect at the time of use.

All forms including back planks of curb shall be set with upper edges flush with specified alignment and grade of the finished surface of the improvements to be constructed, and all forms shall be not less than a depth equivalent to full specified thickness of the concrete to be placed.

Forms shall be held securely in place by means of metal stakes driven in pairs at intervals not to exceed three feet (3'), one at the front form and one at the back form. Clamps, spreaders, and braces shall be used to the extent as may be necessary to insure proper form rigidity. Forms for walk and similar work shall be firmly secured by means of stakes driven at intervals not to exceed four feet (4'). Form stakes shall be of sufficient size and be driven so as to adequately resist lateral displacement.

Commercial form clamps for curb and gutter may be used provided they fulfill the requirements specified herein.

Pump trucks may be used upon approval of the Engineer. Prior to approval, the Contractor must demonstrate to the satisfaction of the engineer that the pumping equipment will not segregate, or in any other way degrade, the concrete. Additional test samples for such alternate placement methods may be taken from the discharge side of the machine for compressive strength determination assurance tests.

Article 2.3 Construction

A. Erecting Forms

All forms shall be set to the lines, grade, and dimensions shown on the Drawings. The forms shall be thoroughly braced and secured to resist deformation or displacement under load, and shall be installed to permit easy removal without hammering or prying against the fresh concrete. The top of the forms shall not deviate more than one-eighth inch (1/8") in ten feet (10'), and the alignment of forms shall be within one-fourth inch (1/4") in ten feet (10').

Before placement of concrete, steel forms shall be lightly oiled with a good grade of form oil. Excess oil shall be removed by wiping with clean rags, dampened in diesel or fuel oil. Wooden forms may be oiled in the same manner as metal forms, or they may be watered immediately in advance of the placement of concrete. Watering of the form shall be done with clean water of the same quality as that specified for mixing water, and only when the atmospheric temperature is not less than forty degrees (40°) Fahrenheit. Concrete shall not be placed until all forms have been inspected and approved by the Engineer. Wherever form work is exposed to pedestrian traffic, bridges (not attached to the forms) shall be provided

at all regular pedestrian crossings where it is required to maintain safety standards. Barricades and other safety features shall be installed as necessary.

B. Placing Concrete

Prior to the delivery of the first load of concrete for curbs, the Contractor shall furnish rigid straightedges, ten feet (10') or sixteen feet (16') in length, to the Engineer for checking surface uniformity. String shall not be used as a straightedge. Surface irregularities, as measured along the top face of curb and the curb pan, shall not exceed three-sixteenth inch (3/16") within ten feet (10'), or five-sixteenth inch (5/16") within sixteen feet (16'). Non-conforming surfaces shall be subject to rejection by the Engineer. All surfaces rejected by the Engineer shall be corrected by the Contractor at the Contractor's expense.

The subgrade shall be properly compacted and brought to specified grade in accordance with the Drawings before placing concrete. The subgrade shall be thoroughly dampened immediately prior to the placement of the concrete. Forms shall not be splashed with concrete in advance of placing.

Concrete shall be discharged from transport vehicle to the point of final placement in a continuous manner as rapidly as practicable. The rate of placement shall not exceed the rate at which the various placing and finishing operations can be performed in accordance with these Specifications. Concrete shall not be allowed to free fall more than three feet (3').

If concrete is to be placed by the extruded method, the Contractor shall demonstrate to the satisfaction of the Engineer that the machine is capable of placing a dense, uniformly compacted concrete to exact section, line and grade. Extruded curb which does not meet all requirements of the Contract Documents, shall be replaced at the Contractor's expense.

C. Stripping Forms and Finishing

The face form of the curb shall be stripped at such time in the early curing as will enable inspection and correction of all irregularities that appear thereon.

Forms shall not be removed until the concrete has set sufficiently to retain its true shape. The face of the curb shall be troweled with a tool cut to the exact section of the curb and at the same time maintain the shape, grade, and alignment of the curb. Both front and back edges shall be troweled to a radius of one-half inch (1/2"). Final finish shall be obtained by brooming the surface, including the troweled edge to a gritty finish after all free moisture has disappeared from the surface. Sprinkling of cement or sand for blotting will not be permitted.

It is the intent of this Specification to insure the highest quality of workmanship in the construction and finishing of P.C.C. curb and gutter.

Unightly or poorly finished surfaces will be considered grounds for rejection of the Work. The top and/or face and gutter of the finished concrete surfaces shall be true and straight, of uniform width and free of cracks, humps, sags, or other irregularities. The finished concrete surface shall not vary more than two-hundredths of a foot (0.02') from a ten foot (10') straight edge, except at grade changes or curves. No freestanding water is permitted on slopes at or greater than one percent (1%). No freestanding water deeper than one-sixteenth inch (1/16") is permitted on slopes of less than one percent (1%). The Contractor shall flow test all new concrete curb and gutter. Curb and gutter failing to meet this requirement will be rejected.

All defective areas shall be removed and replaced at the Contractor's expense, unless permission to patch is granted by the Engineer. Such permission shall not be construed as an acceptance of the Work or as a waiver of the Engineer's right to require the complete removal of the Work, if in his opinion the patch does not satisfactorily restore the quality or appearance of the surface.

Should patching be permitted, the area shall be chipped clean to a depth of one inch (1") perpendicular to the surface and saturated with clean water prior to being patched. The patch shall be made with a mortar extracted from fresh concrete by passing it through a three-eighths inch (3/8") screen. The mortar shall be thoroughly compacted and screeded off slightly higher than the surrounding surface to allow for contracting or setting after the maximum shrinkage has taken place. After one (1) to two (2) hours, the patch shall be troweled to the same finish as the surrounding area and shall be cured as specified herein. The use of special patching material will be permitted if approved by the Engineer.

D. Curing

Curing compounds shall be applied to all exposed surfaces immediately after finishing. Transparent curing compounds shall contain a color dye of sufficient strength to render the film distinctly visible on the concrete for a minimum period of four (4) hours after application.

If, at any time during the curing period any of the forms are removed, a coat of curing compound shall be applied immediately to the exposed surface. The curing compound shall be applied in sufficient quantity to obscure the natural color of the concrete. Additional coats shall be applied if the Engineer determines that the coverage is not adequate. The concrete shall be cured for the minimum period of time set forth below.

Curb and gutter constructed of Type I/II Portland Cement Concrete must have been placed and finished a minimum of seven (7) days prior to material being distributed against, or vibrated (compaction) adjacent to the structure.

Curb and gutter constructed of Type III Portland Cement Concrete must have been placed and finished a minimum of three (3) days prior to any material being distributed against, or vibrated (compaction) adjacent to the structure.

When forms are removed before the expiration of the curing period, the edges of the concrete shall be protected with moist earth, or sprayed with curing compound.

Other standard methods of curing the curb and gutter may be used upon approval of the Engineer. Concrete shall not be placed unless curing compounds and necessary equipment for applying such is on the Project site.

E. Expansion and Contraction Joints

1. Expansion Joints

Expansion joints shall be placed along all structures, as shown in the Drawings and/or Standard Details, and around all features that project into, through, or against the concrete. An expansion joint shall be constructed at the intersection of sidewalks; between sidewalk crossings and sidewalks; between curbs and sidewalks (except parallel curb); and at the beginning and end of curb returns. Additionally expansion joints shall be constructed every fifty feet (50') where the sidewalk span exceeds seventy-five feet (75') and expansion joints are not required for the above listed reasons. Expansion joint material shall conform to the requirements of ASTM D-1751 (AASHTO M-213). Expansion joints shall not exceed one half inch plus or minus one-eighth inch ($1/2" \pm 1/8"$) in width. Expansion joint material shall extend the full width of the structure and shall be cut to such dimensions that the base of the expansion joint shall extend to the subgrade and the top shall be depressed not less than one-quarter inch ($1/4"$) nor more than one-half inch ($1/2"$) below the finished surface of the concrete. The material shall be of one (1) piece in the vertical dimension and shall be securely fastened in a vertical position to the existing concrete face against which fresh concrete is to be placed. After the concrete has set, the expansion joints shall be filled flush to the finish concrete surface with an approved polyurethane sealant applied according to the manufacturer's recommendation.

Before sealing, the joint shall be cleaned of all dirt, gravel, concrete mortar, and other extraneous material. Sealing shall be done in a neat workmanlike manner.

2. Contraction Joints

Transverse contraction joints, cut to a depth of one inch (1") prior to the final set of the concrete, shall be tooled in the sidewalks at intervals of five feet (5'), and at ten feet (10') intervals in the curb and gutter. Where the sidewalk adjoins the curb (parallel to it), contraction joints in the sidewalk and curb shall be made to match where practicable.

Article 2.4 Measurement

Curb or integral curb and gutter shall be measured per linear foot along the face of the curb. Mountable (rolled) curb and gutter shall be measured per linear foot along the gutter line. Portland Cement Concrete (P.C.C.) Valley Gutter shall be measured along the straight flow line between expansion joints "A and B" and from expansion joint "C" to the intersection of this flow line (point "D") as shown on the Standard Detail. Curb containing steel curb facing shall be measured per linear foot along the face of the curb and the designation "Steel Curb Facing" shall be included in the "Type" description of the pay item.

Medians with curb noses shall be measured as follows: P.C.C. curb and gutter per linear foot, curb noses including yellow paint, as units complete in place.

Parking stops shall be measured as units complete in place.

Article 2.5 Basis of Payment

Payment for this Work shall be in accordance with Division 10, Section 10.07 - Measurement and Payment and shall include full payment for all Work described in this Section.

Payment shall be made under the following units unless otherwise specified:

ITEM	UNIT
P.C.C. Curb and Gutter (Type)	Linear Foot
P.C.C. Valley Gutter	Linear Foot
Curb Nose	Each
Parking Stop	Each

Extra payment will not be made for depressed curb or special sections.

SECTION 30.03 PORTLAND CEMENT CONCRETE SIDEWALKS

Article 3.1 Description

The Work covered under this Section consists of all Work necessary for the provision of Portland Cement Concrete sidewalks.

Article 3.2 Materials

The Portland Cement Concrete, joint filler, reinforcing steel, and curing materials shall conform to Section 30.01, Article 1.3 - Materials. Concrete mix for sidewalks shall conform to the requirements for Class A-3.

Article 3.3 Construction

A. Excavation and Embankment

Excavation and embankment for sidewalks shall be as described in Division 20 - Earthwork. Where directed by the Engineer, unsuitable material in the subgrade shall be removed to a specific depth and then backfilled with classified fill. Payment will not be allowed for excavation below grade or for backfill materials required when such excavation is caused by negligence of the Contractor.

Embankment shall be compacted to ninety-five percent (95%) maximum density in accordance with Division 20, Section 20.01, Article 1.5 - Compaction Standards. In areas that are inaccessible to normal compaction equipment, approved tampers shall be used.

Before the forms are set, the subgrade shall be graded to within one inch (1") of established grade and the area between the sidewalk and the adjacent private property line shall be shaped to line, grade, and section shown on the Drawings.

B. Forms and Fine Grading

Forms shall conform to requirements outlined in Section 30.02 - Portland Cement Concrete, Curb and Gutter, and Valley Gutter. Wood forms against unexposed concrete surfaces shall be No. 2 Common Lumber or better. Those against surfaces to be exposed shall be dressed and matched boards of uniform thickness, and widths not exceeding ten inches (10"). Rigid, nonporous and waterproof sheet material may be used provided the end result will be a smooth unmarked concrete surface without waves, fins or other noticeable markings.

Plywood conforming to the requirements for form work, as set forth by the American Plywood Association, may be used against both exposed and unexposed concrete surfaces. This plywood shall be not less than five (5) ply and at least nine-sixteenths inch (9/16") thick. Low areas in the subgrade shall be backfilled with classified fill or with suitable native material as directed by the Engineer. The backfill shall then be compacted to ninety-five percent (95%) maximum density and

any dry areas in the subgrade shall be thoroughly dampened prior to the time the concrete is placed. No payment will be made for water, and the work of placing and cost thereof shall be considered as incidental to the construction of the concrete sidewalk.

C. Placing and Finishing Portland Cement Concrete Sidewalk

The concrete shall be spread uniformly between the forms and thoroughly compacted with a steel shod strikeboard. After the concrete has been thoroughly compacted and leveled, it shall be floated with wood floats and finished at the proper time with a steel float. Joints shall be edged with a one-quarter inch (1/4") radius edger and the sidewalk edges shall be tooled with a one-half inch (1/2") radius edger. After final troweling, sidewalk on grades of less than six percent (6%) shall be given a fine hair broom finish applied transversely to the centerline. On grades exceeding six percent (6%), walk shall be finished by hand with a wood float. Walk shall be re-marked as necessary after final finish to assure neat uniform edges, joints, and score lines. Unsightly, poorly finished, and sidewalk failing to meet the requirements of the Drawings, Specifications, and this Section will be rejected.

The sidewalk shall be divided into panels by scoring one inch (1") deep every five feet (5'). Refer to Section 30.02, Article 2.3, SubArticle E - Expansion and Contraction Joints for requirements for contraction and expansion joints. The expansion joints shall be placed at all structures such as catch basins and manholes, at driveways, and at all points of tangency and points of curvature.

Additional requirements for placing and finishing concrete in cold weather shall be as outlined in Section 30.01, Article 1.9 - Weather Limitations.

For all other exposed aggregate concrete sidewalks, Contractor shall float and trowel all surfaces to receive the exposed aggregate finish. Seeding the surface with aggregate shall not be allowed. After the concrete has taken its initial set, the surface aggregate shall be exposed using a water fog spray and brooms to remove the surface matrix. The coarse surface aggregate shall be exposed very lightly, approximately one-sixteenth inch (1/16"). After the concrete has taken its final set, a weak acid wash shall be applied to clean and wash the exposed aggregate surfaces. The weak acid wash shall be thoroughly neutralized and flushed from the finished surface. Under no circumstances shall Contractor allow the acid wash to enter the storm drain lines.

Contractor shall protect adjacent construction, plantings, finishings, structures, and the public from damage and harm due to the acid wash. The finished appearance of the exposed aggregate concrete sidewalk shall produce an appearance and texture that matches the adjacent exposed aggregate sidewalk. Any significant difference in texture or appearance between two adjacent concrete panels, as determined by the Engineer, shall result in removal and replacement of concrete panels by Contractor at no additional cost.

Contractor shall provide a two foot by two foot (2' x 2') exposed aggregate concrete test panel prior to constructing the exposed aggregate concrete sidewalk. Location of the test panel will be on-site as approved by the Engineer. Notification of providing this test panel shall be made to the Engineer no less than 24 hours prior to making the test panels to allow the Engineer and materials analysis personnel to be present. The Engineer may require the Contractor to provide additional panel(s) if the test panel does not produce an appearance that matches the adjacent exposed aggregate sidewalk.

Providing the test panel and any other required test panel shall be considered incidental to the bid item "P.C.C. Sidewalk 4" Thick (Exposed Aggregate)" and no separate payment shall be made.

D. Curing and Protection

The materials and procedures outlined in Section 30.02, Article 2.3 - Construction, shall prevail. The curing agent shall be applied immediately after finishing and be maintained for a period of seven (7) days. The curing agent(s) and/or concrete mixtures shall in no way deter or prevent final finishing of concrete. The use of surface retarders may be permitted if application methods are accepted by the Engineer, in writing, no less than twenty-four (24) hours prior to concrete placement.

The Contractor shall have readily available sufficient protective covering, such as waterproof paper or plastic membrane, to cover the pour of an entire day in event of rain or other unsuitable weather.

The sidewalk shall be protected against damage or defacement of any kind until it has been accepted by the Owner. Sidewalk which is not acceptable to the Engineer because of damage or defacement shall be removed and replaced at the expense of the Contractor.

Additional requirements for curing in cold weather shall be as outlined in Section 30.01, Article 1.9 - Weather Limitations.

Article 3.4 Measurement

Sidewalk: Sidewalks shall be measured per square yard, complete in place, for both four (4") and six inch (6") thicknesses.

Sidewalk Retaining Walls: Sidewalks of specified thickness constructed in conjunction with sidewalk retaining walls constructed in accordance with Section 30.05 – Structures and Retaining Walls, shall be measured per square yard from the face of retaining wall, accepted in place.

Article 3.5 Basis of Payment

Payment for this item shall be in accordance with Division 10, Section 10.07 - Measurement and Payment and shall include full payment for all Work described in this Section.

Payment shall be made under the following units:

ITEM	UNIT
P.C.C. Sidewalk (Thick) (Type Finish)	Square Yard

SECTION 30.04 PORTLAND CEMENT CONCRETE CURB RAMPS

Article 4.1 General

The Work under this Section consists of performing all operations pertaining to furnishing and constructing Portland Cement Concrete curb ramps with a detectable warning surfacing in conformance with the Drawings. The ramps shall comply with the Americans with Disabilities Act Title II as identified in 28 CFR Part 35 – Nondiscrimination on the Basis of Disability in State and Local Government Services.

Article 4.2 Materials

A. General

The Portland Cement Concrete (P.C.C.) materials and installation shall conform to the requirements of Section 30.03 - Portland Cement Concrete Sidewalk and the Drawings. The P.C.C. shall have a slump range of four to seven inches (4" to 7") to permit solid placement of the tactile warning panel. An overly wet mix will cause the tactile warning panel(s) to float. Contractor shall not add color to the concrete unless specified in the Drawings.

The Contractor shall not apply a troweled pattern to the curb ramps. Contractor shall provide a coarse broom finish for the ramps perpendicular to direction of pedestrian traffic.

B. Detectable Warning Panel

Each detectable warning panel shall have a truncated domed surface twenty-four inches (24") in depth for the width of the ramp. The truncated domes shall have a height of two-tenths inch (0.2"), a diameter of nine-tenths inch (0.9"), a center-to-center spacing of one and six-tenth inches (1.6") minimum and two and four-tenth inches (2.4") maximum, and a base-to-base spacing of sixty-five one-hundredth inch (0.65"), measured between the most adjacent domes.

Contractor shall provide panels federal yellow in color, or approved equal. The specified color shall be homogeneous throughout the panel.

Contractor shall provide Armor Tile Cast-In-Place In-Line Dome Tactile Panel detectable warning panel(s), manufactured by:

Engineered Plastics, Inc.
300 International Drive, Suite 100
Williamsville, NY 14221
Phone: 1-800-682-2525

Local Contact:
Polar Supply Company, Inc.
300 E. 54th Avenue
Anchorage, Alaska 99518-1230
Phone: 907-563-5000
Fax: 907-562-7001

or a gray cast iron detectable warning plates, or panels (s), manufactured by:

Neenah Foundry Company, Inc.
4107 E. Madison Street
Phoenix, AZ 85034
Phone: 1-866-765-0850

OR East Jordan Iron Works, Inc.
301 Spring Street
East Jordan, MI 49727
Phone: 1-800-626-4653

Local Contacts:
Ferguson Enterprises, Inc.
151 East 95th Avenue
Anchorage, Alaska 99515
Phone: 907-273-2100
Fax: 907-273-2110

OR Hughes Supply, Inc.
440 West 40th Avenue
Anchorage, Alaska 99503
Phone: 907-563-3315
Fax: 907-562-2175

or an approved equal.

Article 4.3 Construction

The Contractor shall construct each curb ramp and install the detectable warning panel(s) in conformance with the Contract Documents and the manufacturer's recommendations.

No later than five (5) days prior to construction of the curb ramps, Contractor shall submit to the Engineer for review and approval, a layout drawing for each curb ramp to resolve issues related to pattern repeat, tile cuts, expansion joints, control joints, ramp curves, ramp end returns and surface interfaces, and truncated dome spacing.

Contractor shall install and finish the P.C.C. in accordance with the Contract Documents prior to installation of the detectable warning panel(s). Contractor shall tamp the plate(s) or panel(s) with a small sledge hammer with a two inch by six inch by twenty inch (2" x 6" x 20") wood tamping plate, or lightly vibrate into the fresh concrete to ensure that the panel's field level (base of truncated dome) is flush with the adjacent concrete and top back of curb. Contractor shall ensure that the panel's field level is flush with the adjacent concrete surface, proper water drainage is provided, and potential tripping hazards are eliminated. Contractor shall ensure that the back edge of the detectable warning panel(s) form a smooth arc and is parallel to the top back of the curb.

Immediately after the panel placement, Contractor shall check and adjust accordingly the panel's or plate(s) field level to be flush with the adjacent concrete surface. Following final field-level adjustment(s), place suitable twenty-five (25) pound weights, conforming to the manufacturer's recommendations, on each panel and additional weights at panel-to-panel joints as necessary to provide a solid contact between the panel underside and the concrete.

During and after the panel installation and concrete curing time, Contractor shall ensure that there is no walking, leaning, or any external forces placed on the panel, thereby causing a void between the underside of the panel and the concrete.

After the concrete has cured, Contractor shall remove protective plastic wraps. If "concrete bleeding" occurs between the panels, Contractor shall remove the residue without damage to the panel surfaces, in accordance with the manufacturer's recommendation.

Contractor shall maintain, on-site, an electronic level, a five foot (5') diameter circle template, and a three foot by five foot (3'x5') rectangular template. Template may be of any material, including paper. Contractor shall, when requested, demonstrate to the Engineer that there are adequate landing and turning areas that meet the dimensions and slopes required on the Drawings.

Backfill and grade areas disturbed by curb ramp construction and restore ground surface as shown on Drawings.

Article 4.4 Tolerances

In accordance with the Americans with Disabilities Act Public Rights-of-Way Accessibility Guidelines (PROWAG), dimension not stated as "maximum" or "minimum" are absolute. All dimensions are subject to conventional industry tolerances, except where the requirement is stated as a range with specific minimum and maximum end points.

Conventional industry tolerances recognized by the ADAAG include those for field conditions that may be a necessary consequence of a particular manufacturing process. Information on specific tolerances may be available from industry or trade organizations, code groups, building officials, and published references. (Example: American Concrete Institute Standard Specifications for tolerances for concrete construction and materials (ACI-117)).

Article 4.5 Measurement

The Work paid for under "P.C.C. Curb Ramp" shall be measured as furnished, constructed, finished, and accepted in place for each installation or the actual horizontal square yardage of curb ramp (including curb ramp under detectable warnings) and back curb.

The Work paid for under "Detectable Warnings" is measured by the actual horizontal square footage of detectable warning tiles furnished, installed, and accepted in place.

When P.C.C. Curb Ramp is paid per each, the Detectable Warnings are incidental to each installation and no separate payment shall be made.

Article 4.6 Basis of Payment

Payment for this Work shall be in accordance with Division 10, Section 10.07 - Measurement and Payment, and shall include full payment for all Work described in this Section.

Payment for restoration of existing ground surface disturbed by curb ramp construction is made under "A.C. Pavement," "P.C.C. Sidewalk," "Topsoil," and "Seeding," as applicable. No separate payment is made for backfilling and grading in preparation of paid surface treatment. No separate payment is made for backfilling and grading in locations where the existing surface is gravel.

Payment shall be made under the following unit:

ITEM	UNIT
P.C.C. Curb Ramp (Type)	Each
P.C.C. Curb Ramp (Type)	Square Yard
Detectable Warnings	Square Foot

SECTION 30.05 STRUCTURES AND RETAINING WALLS

Article 5.1 Description

The Work under this Section consists of the construction of Portland Cement Concrete structures and retaining walls.

Article 5.2 Construction

A. Reinforcing Steel

Reinforcing bars shall be bent cold and shall conform accurately to the shape and dimensions shown on the diagram. Bent-up bars, unless otherwise specified, shall be bent up at an angle of forty-five degrees (45°). In no case shall the radius of any bend be less than four (4) times the diameter of the bar.

The reinforcement shall be positioned as indicated on the Drawings or as hereinafter specified. It shall be rigidly blocked and wired in place, using metal supports or concrete blocks and securely tied at each intersection with annealed iron wire of at least twelve (12) gauge.

Splicing bars at points not indicated on the Drawings will not be permitted except as an emergency measure and with the consent of the Engineer. Such splices shall be at the points of minimum tensile stress and the lap shall be not less than thirty-six (36) bar diameters.

Bar lists and Bending schedules shall be furnished by the Contractor for approval of the Engineer. Materials shall not be ordered until such lists and bending diagrams have been approved by the Engineer. The approval of order lists and bending diagrams will in no way relieve the Contractor of responsibility for the correctness of such lists and diagrams. Any expense incidental to the revision of material furnished in accordance with such lists and diagrams, to make it comply with the design drawings, shall be borne by the Contractor.

B. Forms

Forms shall conform to the shape and dimensions shown on the Drawings and shall be accurately set to line and grade. All sheeting in contact with concrete surfaces shall be matched tongue and groove lumber, sized to uniform thickness and free from wane, warp, splits, loose knots or other defects which will prevent obtaining a smooth, tight form. Forms for exposed surfaces shall be lined with plywood conforming to the requirements for form plywood as specified by the American Plywood Association. All plywood lining shall be used in as wide pieces as possible. Areas less than four feet (4') in width shall be lined with a single width of plywood. Joints in lining and backing shall not occur at the same place and the abutting edges of adjacent sheet shall be nailed to the same board.

Joints in the lining shall be filled with cold water putty, patching plaster, plastic wood, or other plastic filler satisfactory to the Engineer. Lining material may be re-used if it is in satisfactory condition, well cleaned, re-oiled, and if specific permission from the Engineer is obtained for each separate operation.

All forms shall be securely tied with bolts or rods in such manner that after stripping, such bolts or rods may be either entirely removed or may be removed for a distance at least one inch (1") below the concrete surface. Such bolts or rods shall be threaded and provided with nuts to prevent slipping and to provide adjustments. No wire ties or clamping devices shall be permitted.

Forms for walls, etc., shall have large cleanout openings at their lowest points, which shall not be closed until just before placing concrete. All forms shall be thoroughly cleaned and soaked with water immediately before filling.

Weep drains shall be provided by the Contractor and installed as shown on the Drawings.

C. Placing

Concrete shall be placed by means of a bottom dumping bucket, cart, concrete chute, or tremie. At no time shall concrete have a free fall or more than three feet (3'). The concrete shall be brought up in approximately horizontal layers. The concrete shall be placed continuously from one side or end of the section to the other, using precaution to put the full load upon any given area of form as rapidly as possible. The rate of delivery of concrete to the work shall be such as to insure continuity of placement. No partially completed surface shall be allowed to stand more than forty-five (45) minutes before continuing the placing of concrete thereon.

D. Compacting Concrete

All concrete shall be thoroughly spaded, especially along the forms, to prevent the formation of gravel pockets and to permit the escape of trapped air. In addition to spading, the Contractor shall also provide suitable internal vibrating tampers of the type designed to be placed directly in the concrete. Vibration shall be such that the concrete becomes uniformly plastic. Vibrators shall be inserted to a depth sufficient to vibrate the bottom of each layer effectively, but shall not be allowed to penetrate partially hardened concrete which will not become plastic under the vibrator action, nor shall the vibrator be applied directly to steel which extends into partially hardened concrete. Placing of concrete shall not commence until the vibrator is on the job site and the mechanical efficiency of the vibrator is proven in the presence of the Engineer.

E. Finishing Concrete

All irregularities on exposed surfaces such as gravel pockets, bolt holes, etc., shall be neatly painted with mortar of the same proportions as used in the concrete. The

surface film of all such patches shall be rubbed off after initial setting has taken place.

All exposed surfaces shall, after irregularities have been corrected, be thoroughly wetted and brushed with a grout composed of one (1) part fine sand and one (1) part cement. It shall then be kept wet for forty-eight (48) hours.

All outside edges are to have three-quarter inch (3/4") chamfered corners, unless noted otherwise. They shall be obtained by putting a triangular strip of wood in the corners of the forms.

F. Joints, Horizontal and Vertical

Joints shall be made in walls or structures as indicated on the Drawings or where directed by the Engineer. If not indicated on the Drawings, the maximum distance between contraction joints shall be twenty-five feet (25'), and the maximum distance between expansion joints shall be fifty feet (50'). Where expansion joints are required, one-half inch (1/2") precast expansion joint material conforming to the requirements of ASTM D-1751 (AASHTO M-213) shall be used. The walls shall be poured one section at a time. The joint material shall be accurately cut to fit the bulkhead between sections, and nailed to the bulkhead with 6d nails. These nails shall be driven into the lumber only enough to hold the material in place, the heads being embedded in the concrete. The bulkheads between sections shall be removed not sooner than twelve (12) hours after the concrete has been placed and the nail points clinched into the joint material.

At the surface of the wall, unless otherwise shown, the joint shall end in a V-shaped groove, two inches (2") wide and one inch (1") deep. Unless noted otherwise, all joints will be truly horizontal or truly vertical.

G. Removal of Forms

Unless otherwise directed by the Engineer, forms may be removed from structures and retaining walls, which are not subject to supporting loads, after a period of three (3) days. All other forms shall be removed upon approval of the Engineer.

H. Curing

All exposed surfaces shall be covered by layers of absorptive burlap, mats or other approved material to a thickness weighing not less than fourteen (14) ounces per square yard, immediately after finishing. The cover material shall be kept saturated with clean water for a minimum initial curing period of twenty-four (24) hours.

Following this initial curing, the concrete shall be completely covered with a plastic waterproof membrane, or equal, for an additional six (6) days. Liquid spray type waterproof membrane will not be considered a satisfactory material for curing concrete used for retaining walls or structures.

I. Waterproofing

Unless otherwise specified, the back side of retaining walls and backfilled surfaces of other structures shall be painted with two (2) coats of a cold bituminous waterproof coating which shall be approved by the Engineer prior to application. Application shall be with a stiff masonry type brush, or as recommended by the manufacturer.

J. Earthwork

All earthwork involved in the construction of retaining walls shall be constructed as specified in Division 20 - Earthwork.

Excavation for retaining walls and structures shall be to the limits shown on the Drawings. Where limits are not indicated, excavation shall be sufficient to properly construct the work.

Where directed by the Engineer, unsuitable material in the subgrade shall be removed to a specific depth and then backfilled with classified fill.

The subbase under footings shall be compacted to ninety-five percent (95%) density at optimum moisture content in accordance with Section 30.01, Article 1.5 - Subbase.

Backfilling the lower portion of structures and retaining walls shall not begin until fourteen (14) days after concrete placement. Where High-Early Strength Cement is used, backfilling the lower portion of structures and retaining wall shall not begin until four (4) days after concrete placement. Waterproofing shall not be left exposed for longer than twelve (12) days before backfill. Where drain holes or drain tile are involved, or where the Engineer may direct, a filter fabric shall be used in conjunction with a six inch (6") layer of coarse gravel which shall be spread and compacted around the drains in such a manner that earth will not clog the voids in the gravel. The remainder of the backfill shall be classified fill placed in layers not exceeding one foot (1') in thickness. Each layer shall be thoroughly rammed with a rammer not more than ten inches (10") in diameter and weighing not less than forty (40) pounds, or with an approved mechanical tamper. Unsuitable earth or vegetable matter shall not be used as backfill. Filling with loose earth and hydraulic jetting will not be allowed except by written permission of the Engineer. Imported material for backfill shall conform to Division 20, Section 20.21 - Classified Fill and Backfill.

Article 5.3 Measurement

Concrete shall be measured per cubic yard for structures and retaining walls. Measurement will be determined from the neat line dimension. In the case of minor field changes such a changing the length, height, etc., payment shall be based on the same unit price per cubic yard as bid. Measurement shall be determined by the Engineer and Contractor prior to placing concrete. Where sidewalks are constructed in conjunction with

retaining walls, the sidewalk shall be measured under the provisions of Section 30.03 – Portland Cement Concrete Sidewalks.

Article 5.4 Basis of Payment

Payment for this Work shall be in accordance with Division 10, Section 10.07 - Measurement and Payment, and shall include full payment for all Work described in this Section. Extra payment will not be made to the Contractor if he places additional concrete over and above the neat line volume to facilitate his operation and save on form work.

No additional payment shall be made for excavation and backfill around retaining walls and structures. Payment for disposal of unusable excavation shall be in accordance with Division 20, Section 20.10 – Excavation for Traffic Ways. Payment for classified fill shall be made in accordance with Division 20, Section 20.21 – Classified Fill and Backfill.

Payment shall be made under the following unit:

ITEM	UNIT
P.C.C. Structure/Retaining Wall (Class)	Cubic Yard

SECTION 30.06 CONCRETE MASONRY RETAINING WALLS

Article 6.1 Description

The Work covered under this Section consists of the construction of concrete masonry walls on a reinforced, poured Portland concrete footing. This Work includes all excavation, classified fill or backfill, and mechanical compaction.

Article 6.2 Construction

A. Reinforcing Steel

Reinforcing steel shall conform to Section 30.05, Article 5.2 - Construction.

B. Survey

The Contractor shall set control stakes for the footings. The stakes will be set at breaks in grade and on even grade intervals not to exceed fifty feet (50'). They will be marked with the station offset, and the cut or fill to the top of the footing.

C. Forms

Forms may be of wood, metal, or any other material at the option of the Contractor, provided that the forms as set will result in a footing in accordance with thickness, cross section, grade, and alignment as required by the Contract Documents.

Forms may be removed after a period of three (3) days, unless otherwise directed by the Engineer.

D. Excavation and Embankment

Excavation and embankment for Masonry Retaining Walls shall be as described in Section 30.05, Article 5.2, SubArticle J - Earthwork.

E. Constructing Masonry Wall

The Contractor shall omit the head joint in the first course every thirty-two inches (32") O.C. to provide for weep holes.

All cells of the concrete masonry retaining wall shall be filled solid with grout. The grout shall develop a maximum compressive strength of 2,000 P.S.I. in 28 days. The grout mix shall be of a fluid consistency and mixed in the ratio by volume of one (1) part Portland cement, three (3) parts concrete sand, and two (2) parts No. 8 Coarse Aggregate. The concrete sand is to conform to the gradation requirements of AASHTO M-6. The coarse aggregate is to comply with gradation requirements as follows:

Coarse Aggregate Gradation Requirements

<u>Sieve Size</u>	<u>Percent Passing by Weight</u>
1/2"	100
3/8"	85-100
#4	10-30
#8	0-10
#16	0-5

Mortar shall be freshly prepared and uniformly mixed in the ratio by volume of one (1) part cement, one-half (1/2) part lime putty, and four and one-half (4-1/2) parts sand and shall conform to requirements of ASTM C-270.

The use of admixtures shall not be permitted in mortar or grout unless substantiating data is submitted and approved by the Engineer.

Masonry units shall be Grade A Units, conforming to the requirements of ASTM C-90. These units shall be sound, dry, clean, and free from cracks when placed in the structure. Where masonry unit cutting is necessary, all cuts shall be neat and true.

Portland Cement Concrete used in footings, shall conform to Section 30.01, Article 1.3 - Materials.

The starting joint on the footing shall be laid with full mortar coverage on the bed joint. All mortar joints shall be straight, clean and uniform in thickness and shall be tooled.

Tooling shall be done with a round bar to produce a dense, slightly concave surface well bonded to the block at the edges. Tooling shall be done when the mortar is partially set but still sufficiently plastic to bond. All tooling shall be done with a tool which compacts the mortar, pressing the excess mortar out of the joint rather than dragging it out. Joints which are not tight at the time of tooling shall be raked out, pointed, and then tooled.

If it is necessary to move a unit after it has been set in place, the unit shall be removed from the wall, cleaned and set in fresh mortar.

All capping units shall be set in a full bed of mortar.

F. Curing and Waterproofing

Curing and waterproofing of concrete masonry retaining walls shall conform to the specifications for structures and retaining walls in Section 30.05, Article 5.2, SubArticles H - Curing, and I - Waterproofing.

Article 6.3 Measurement

The item concrete masonry retaining walls shall be on a lump sum basis, complete in place and no measurement of quantities shall be made.

Article 6.4 Basis of Payment

Payment for this Work shall be in accordance with Division 10, Section 10.07 - Measurement and Payment, and shall include full payment for all Work described in this Section.

Payment shall be made under the following unit:

ITEM	UNIT
Concrete Masonry Retaining Walls	Lump Sum

SECTION 30.07 CONCRETE – BUILDING STRUCTURES

Article 7.1 Description

The Work covered in this Section consists of providing all operations pertaining to the mixing and placement of Portland Cement Concrete.

Article 7.2 Materials

A. Portland Cement Concrete, reinforcing steel, curing materials, and miscellaneous concrete Work shall conform to the following paragraphs of Section 30.01, Article 1.3 - Materials:

1. Reinforcing Steel and Steel Dowels

See Section 30.01, Article 1.3, SubArticles A – Reinforcing Steel and B – Welded Steel Wire Fabric.

2. Preformed Expansion and Dummy Joint Filler

See Section 30.01, Article 1.3, SubArticle H – Expansion Joints.

3. Curing Compounds

See Section 30.01, Article 1.3, SubArticle G – Curing Materials.

B. Forms

Forms may be of wood or metal or any other material at the option of the Contractor, provided that the forms as set will result in configurations, dimensions, and proper finish in accordance with the Drawings.

Forms may be removed on the day following pour if the concrete is sufficiently set so that removal can be accomplished without danger of chipping or spalling. All forms shall be cleaned, oiled, and be examined for defects before they are used again.

Article 7.3 Formwork Construction

A. Inspection

Verify lines, levels, and measurements before proceeding with formwork.

B. Preparation

Earthforms - Hand-trim sides and bottoms of earth forms; remove loose dirt prior to placing concrete.

Wood and Prefabricated Forms - Minimize form joints. Symmetrically align joints and make watertight to prevent leakage of mortar for exposed concrete. Arrange and assemble formwork to permit dismantling and stripping so that concrete is not damaged during its removal. Arrange forms to allow stripping without removal of principal shores, where required to remain in place.

C. Erection

Provide bracing to ensure stability of formwork. Strengthen formwork liable to overstressing by construction loads. Camber slabs and beams to achieve ACI 301 tolerances. Provide temporary ports in formwork to facilitate cleaning and inspection. Locate openings at bottom of forms to allow flushing water to drain. Close ports with tight-fitting panels, flush with inside face of forms, neatly fitted so that joints will not be apparent in exposed concrete surfaces. Provide chamfer strips on external exposed corners of beams, joists, and columns. Construct formwork to maintain tolerances in accordance with ACI 301.

D. Application of Form Release Agent

Apply form release agent on formwork in accordance with manufacturer's instructions. Apply prior to placing reinforcing steel, anchoring devices, and embedded items. Do not apply form release agent where concrete surfaces are scheduled to receive special finishes which may be affected by agent. Soak contact surfaces of untreated forms with clean water. Keep surfaces wet prior to placing concrete.

E. Inserts, Embedded Parts, and Openings

Provide formed openings where required for Work embedded in, or passing through, concrete. Coordinate Work of other sections in forming and setting openings, slots, recesses, chases, sleeves, bolts, anchors, and other inserts. Install accessories in accordance with manufacturer's instructions, level, and plumb. Ensure items are not disturbed during concrete placement.

F. Form Removal

Do not remove forms, shoring, and bracing until concrete has sufficient strength to support its own weight, and construction and design loads which may be imposed upon it. Remove load-supporting forms only when concrete has attained seventy-five percent (75%) of required 28-day compressive strength provided construction is reshored. Reshore structural members due to design requirements or construction conditions to permit successive construction. Remove formwork progressively so no unbalanced loads are imposed on structure. Do not damage concrete surfaces during form removal. Store reusable forms for exposed architectural concrete to prevent damage to contact surfaces. Remove formwork in same sequence as concrete placement to achieve similar concrete surface coloration.

G. Cleaning and Tightening

Thoroughly clean forms and adjacent surfaces to receive concrete as erection proceeds and just before concrete placement. Remove chips, wood, sawdust, dirt, and other debris and ensure that water and debris drain from formwork through cleanout ports.

During cold weather, remove ice and snow from forms. Do not use deicing salts. Unless within a heated enclosure, do not use water to clean out forms. Use compressed air to remove foreign matter.

Retighten forms immediately after concrete placement as required to eliminate mortar leaks.

Article 7.4 Concrete

A. Placing Concrete

Before placing concrete, ensure reinforcing is clean, free of loose scale, dirt, or other foreign coatings which would reduce bond to concrete. Ensure that reinforcing is supported and secured against displacement. Do not deviate from true alignment.

Place concrete in accordance with ACI 304.

Notify the Engineer a minimum of twenty-four (24) hours prior to commencement of concreting operations.

Ensure anchors, seats, plates, and other items to be cast into concrete are placed, held securely, and will not cause hardship in placing concrete. If problems are found, rectify same and proceed with Work.

Maintain records of poured concrete items. Record date, location of pour, quantity, air temperature, and test samples taken.

Ensure reinforcement, inserts, embedded parts, formed expansion and contraction joints are not disturbed during concrete placement.

A bonding agent is to be used where pouring against previously placed concrete. Submit manufacturer's product data for the bonding agent to the Engineer for approval. Surface preparation is to be in accordance with the manufacturer's recommendations for the approved product.

Pour concrete continuously between predetermined construction and control joints.

Pour slabs-on-grade in checkerboard pattern or provide control joints to form panels or patterns as shown on the Drawings. If not shown on the Drawings, control joints shall be made by sawing or by approved inserts. Saw cut control joints within twenty-four (24) hours after finishing and use a three-sixteenths inch

(3/16") thick blade, cutting one-fourth (1/4) of slab thickness. Unless otherwise specified or approved, control joint spacing shall not exceed fifteen feet (15').

In locations where new concrete is to be doweled to existing work, lay down dowels as shown on the Drawings, drill holes in existing concrete and embed dowels according to the recommendations of the manufacturer of the approved bonding agent. Submit manufacturer's product data for the bonding agent to the Engineer for approval.

Excessive honeycomb or embedded debris in concrete is not acceptable and the Contractor shall notify the Engineer upon discovery.

Conform to ACI 306 when concreting during cold weather.

Install vapor barrier under interior slabs on grade. Lap joints minimum six inches (6") and seal. Do not disturb or damage vapor barrier while placing concrete reinforcing. If damage does occur, repair areas before placing concrete. Use vapor barrier material, lapped over damaged areas a minimum of six inches (6") and seal.

Screed slabs-on-fill, maintaining surface flatness of maximum one-eighth inch (1/8") in ten feet (10').

B. Patching

Notify the Engineer twenty-four (24) hours in advance to allow inspection of concrete surfaces immediately upon removal of forms. Patch imperfections as directed.

C. Defective Concrete

Modify or replace concrete not conforming to required lines, details, and elevations.

Repair or replace concrete not properly placed resulting in excessive honeycombing and other defects. Do not patch, fill, touchup, repair, or replace exposed concrete except upon express direction of the Engineer for each individual area.

D. Concrete Finishing

Provide standard form finish to all concrete formed surfaces that are to be concealed in the finish work or by other construction.

E. Floor Finishing

Finish concrete floor surfaces in accordance with ACI 302 and ACI 304.

Uniformly spread, screed, and float concrete. Do not use grate tampers or mesh rollers. Do not spread concrete by vibration.

Maintain surface flatness, with maximum variation of one-eighth inch (1/8") in ten feet (10').

In areas with floor drains, maintain floor levels at walls and pitch surfaces uniformly to drains at one-eighth inch (1/8"/ft) per foot, or as directed by the Engineer.

F. Curing and Protection

Beginning immediately after placement, protect concrete from premature drying, excessively hot or cold temperatures, and mechanical injury. Maintain concrete with minimal moisture loss at relatively constant temperature for period necessary for hydration of cement and hardening of concrete.

Article 7.5 Measurement

The item concrete – building structures as identified in the Contract Documents and Drawings shall be measured on a cubic yard basis, complete in place and no separate payment shall be made.

Article 7.6 Basis of Payment

Payment for this Work shall be in accordance with Division 10, Section 10.07 – Measurement and Payment and shall include full payment for all Work described in this Section.

Unit Cost shall be made on the following basis unless otherwise specified:

ITEM	UNIT
Floor Slabs - on grade	C.Y.
Structural Slabs - on grade	C.Y.
Spread Footings	C.Y.
Continuous Footings	C.Y.
Concrete Walls (Inches Thick)	C.Y.

SECTION 30.08 PORTLAND CEMENT CONCRETE CLUSTER MAILBOX BASE

Article 8.1 General

The Work under this Section consists of performing all operations pertaining to furnishing and constructing a cluster mailbox base.

Article 8.2 Materials and Installation

Each cluster mailbox base shall be constructed in conformance with the Drawings. Materials and installation shall meet the requirements of Section 30.03 - Portland Cement Sidewalks and the Drawings.

Article 8.3 Construction

Contractor shall contact the Manager of the Address Management Department, Anchorage District, United State Post Office at 564-2846, forty-eight (48) hours prior to beginning construction of the cluster mailbox base to schedule the final placement of the cluster mailbox unit by the United State Post Office.

Article 8.4 Measurement

The Work shall be measured per each actual cluster mailbox base furnished, constructed, and accepted in place.

Article 8.5 Basis of Payment

Payment for this Work shall be in accordance with Division 10, Section 10.07 - Measurement and Payment and shall include full payment for all Work described in this Section.

Payment shall be made under the following unit:

ITEM	UNIT
P.C.C. Cluster Mailbox Base	Each

SECTION 30.09 CONCRETE PARKING BUMPERS

Article 9.1 Description

This Work item includes the forming, casting, and installation of concrete parking bumpers as shown on the Drawings.

Article 9.2 Material

Reference Section 30.01 - General Provisions.

Concrete class shall be A-3.

Article 9.3 Construction

Contractor shall construct precast concrete parking bumpers in accordance with applicable construction techniques specified in Section 30.02 - Portland Cement Concrete Curb and Gutter, and Valley Gutter. Parking bumpers shall be seven feet (7') long and seven inches (7") tall. Parking bumpers shall be ten inches (10") wide at the base and taper to six inches (6") wide at the top. Parking bumpers shall be firmly set in place with two (2) eighteen inch (18") long #5 rebar.

Article 9.4 Basis of Payment

Payment for this Work shall be in accordance with Division 10, Section 10.07 - Measurement and Payment, and shall include full payment for all Work described in this Section.

Payment will be made under the following unit:

ITEM	UNIT
Concrete Parking Bumpers	Each

SECTION 30.10 COLORED CONCRETE

Article 10.1 General

The Work under this Section consists of providing all operations and materials necessary to install colored concrete. All Work shall be in accordance with this Section and shall be placed at the locations shown on the Drawings.

Article 10.2 Materials

The Portland Cement concrete and curing materials shall conform to Section 30.01, Article 1.3 - Materials, as modified below:

A. Concrete

Concrete mix for imprinted colored concrete shall conform to Section 30.01, Article 1.6 – Mix Requirements for Classes of Concrete, requirements for Class AA-3, normal weight concrete. Contractor shall make white concrete using white cement, white aggregate, and white sand. Contractor shall use Davis Color #160, Brick Red, available from Davis Color, Los Angeles, California or approved equal, at a rate of 5 pounds of color per sack of cement to make colored concrete.

B. Imprint

Where imprinted concrete is called for on the Drawings, the Contractor shall use “Bomanite Running Bond Tile” available from Bomanite Corporation, Palo Alto, California, or another concrete imprinting system of approved equal performance.

C. Expansion Joints

Filler material shall be non-asphaltic material, one-half inch (1/2") wide and four inches (4") deep, with the top one inch (1") strippable. Primer shall be “Externaflex” 1993 or approved equal. Backer rod shall be closed cell polyethylene. Sealant shall be “Externaflex” two-compound urethane, “pour grade” No. 1071-200, or approved equal. Contractor shall use the appropriate sealant color to match the colored concrete, including Brick Red sealant to match the red concrete.

Article 10.3 Construction

The excavation and embankment, forms and fine grading, placing and finishing, curing and protection operations for imprinted colored concrete shall conform to Section 30.03, Article 3.3 – Construction as amended below:

Place imprinted colored concrete in dry weather with temperatures above forty degrees (40°) Fahrenheit.

Where imprinted concrete is called for in the Drawings, the Contractor shall apply the imprinting tool while the concrete is still in the plastic stage of set in conformance with the manufacturer's specifications.

Article 10.4 Measurement

Imprinted colored concrete shall be measured per square yard, complete and in place.

Article 10.5 Basis of Payment

Payment for this Work shall be in accordance with Division 10, Section 10.07 - Measurement and Payment and shall include full payment for all Work described in this Section.

Payment shall be made under the following unit:

ITEM	UNIT
Colored Concrete (Color) (Thickness) (Imprinted)	Square Yard

SECTION 30.11 SIDEWALK JOINT SEALANT

Article 11.1 General

The Work under this Section consists of performing all operations pertaining to preparing and sealing joints in existing sidewalk for the purposes of sealing and repair. This Section is not applicable to joint sealant utilized during the construction of new concrete work.

Article 11.2 Materials

Sealant materials shall be Elastomeric (in accordance with ASTM C-920) long lasting, and resist deterioration caused by weather, street, movement, traffic, and water. Sealant materials shall be approved by the Engineer prior to use. The sealant color shall closely match adjacent concrete sidewalk.

Article 11.3 Construction

Joint sealant shall be applied to joints with dimensions between one-half inch (1/2") and one inch (1") in width, as directed by the Engineer. The sealant shall be applied in conformance with the manufacturer's instructions and to full depth of the joint.

The joints shall be cleaned and all loose material shall be blown out to the full depth of the joint. The interior of the joint shall be completely dried and existing sidewalk surfaces shall be exposed.

Article 11.4 Measurement

The application of joint sealant shall be measured per linear foot of sealant applied as directed by the Engineer for sidewalk patch and repair. Payment for joint sealant used during construction of new concrete work is governed by the appropriate Section for that installation, is considered incidental to that pay item, and no payment shall be made under this Section.

Article 11.5 Basis of Payment

Payment for this Work shall be in accordance with Division 10, Section 10.07 - Measurement and Payment and shall include full payment for all Work described in this Section.

Payment shall be made under the following unit:

ITEM	UNIT
Joint Sealant	Linear Foot

**MUNICIPALITY OF ANCHORAGE
STANDARD SPECIFICATIONS**

**DIVISION 30
PORTLAND CEMENT CONCRETE
STANDARD DETAILS**

**STANDARD CONSTRUCTION SPECIFICATIONS
MISCELLANEOUS
DIVISION 30
INDEX OF STANDARD DETAILS**

30-1	Curb and Gutter Cross Sections
30-2	Curb and Gutter Termination Transition
30-3	Typical Section - Valley Gutter
30-4	Typical Section - Median/Curb Nose
30-5	Steel Curb Facing
30-6	Driveway Curb-cut with Attached Sidewalk
30-7	Driveway Curb Return with Attached Sidewalk
30-8	Perpendicular Curb Ramp
30-9	Parallel Curb Ramp
30-10	Accessible (Type 1A/2A) Curb and Gutter Sections
30-11	Curb Ramp Clearances
30-12	Pedestrian Push Button Access
30-13	Curb Type Retaining Wall - 2' to 3'
30-14	Sidewalk Retaining Wall - 6" to 24"
30-15	Sidewalk Retaining Wall - 2' to 5'

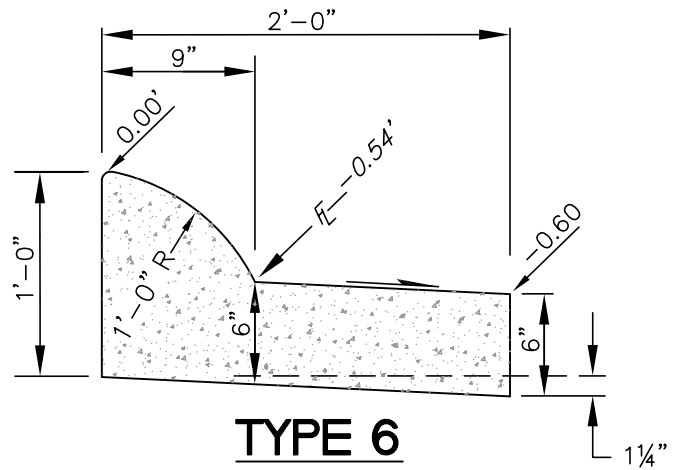
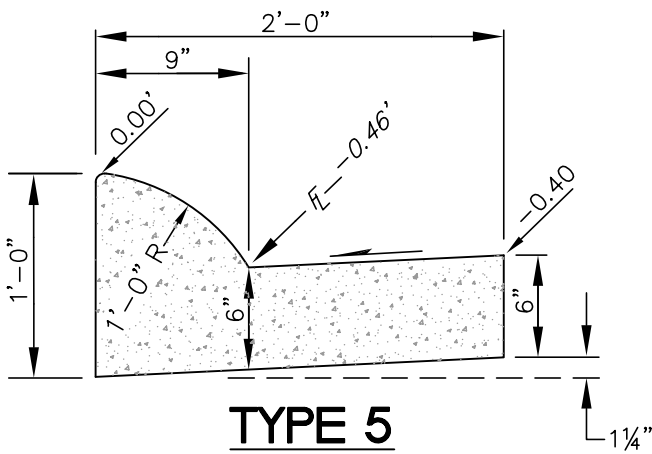
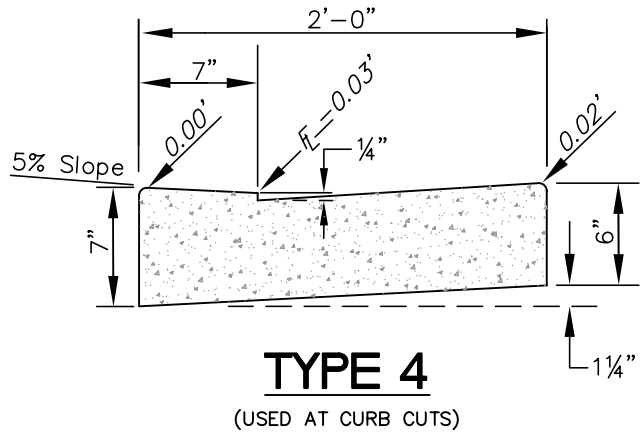
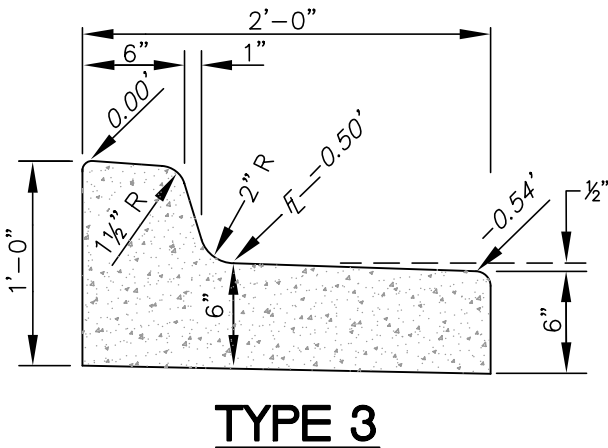
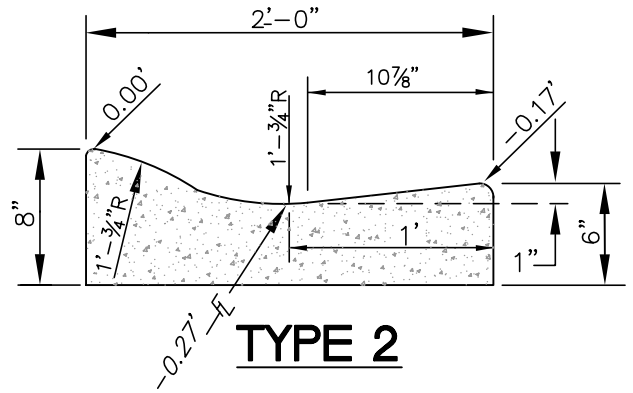
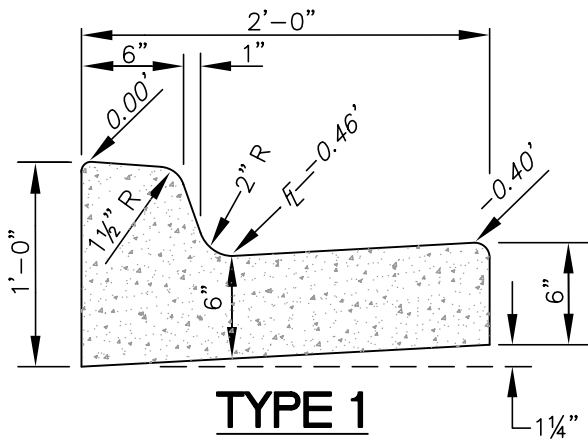

NOTE:

TROWEL BOTH FRONT AND BACK EDGES OF THE CURB & GUTTER TO A RADIUS OF ONE-HALF (1/2) INCH.

REVISION: 12/09 FIXED TYPE 2 CURB & GUTTER

MUNICIPALITY



OF ANCHORAGE

SCALE:
NTS

APPROVED:

REVISED:
12/09

CURB AND GUTTER CROSS SECTIONS

SECTION #
30.02

DETAIL #
30-1

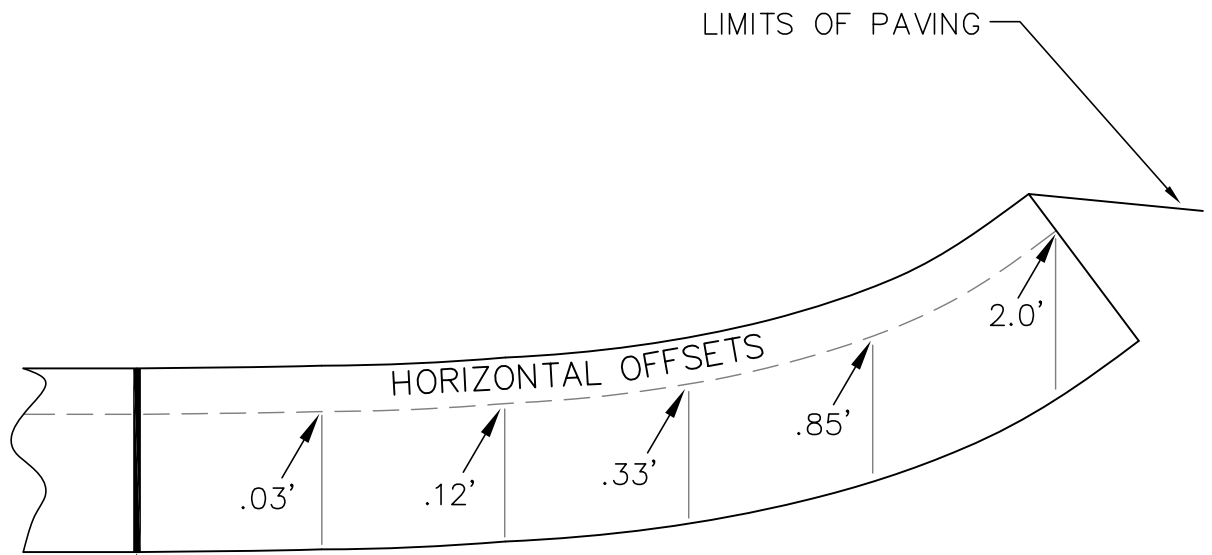

PLAN

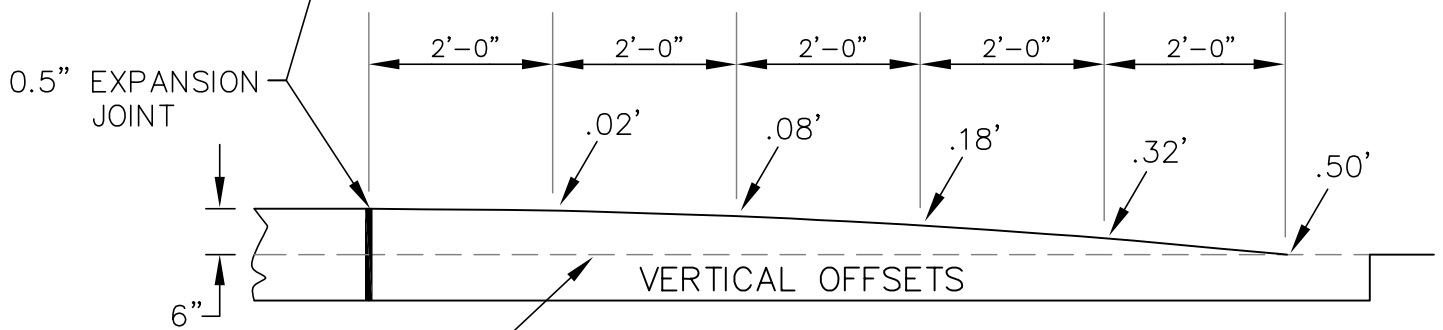

PROFILE

MUNICIPALITY



OF ANCHORAGE

SCALE:
NTS

APPROVED:

REVISED:
10/07

**CURB AND GUTTER
TERMINATION TRANSITION**

SECTION #
30.02

DETAIL #
30-2

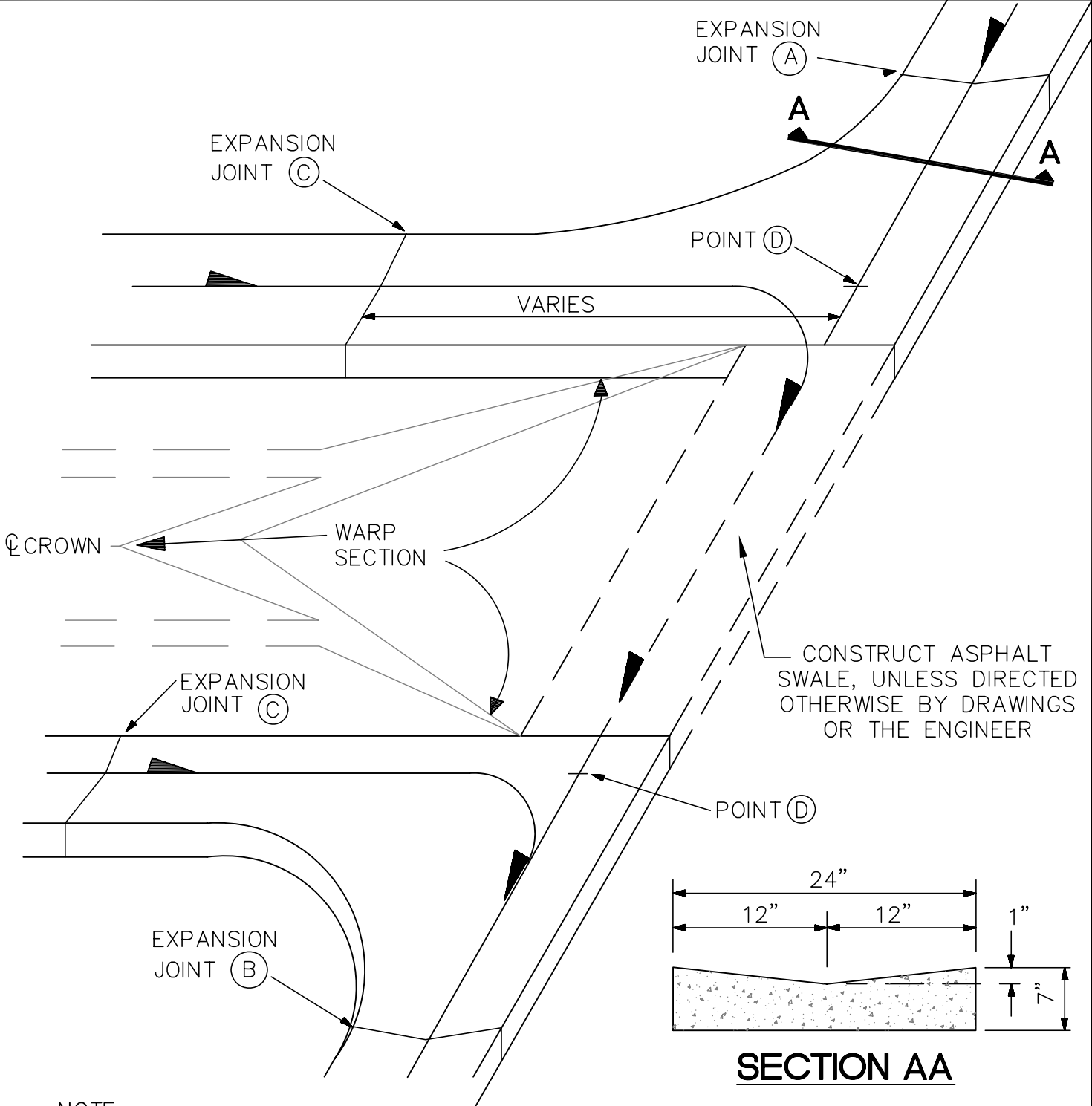

NOTE:
 VALLEY GUTTER SHALL BE PAID PER LINEAR FOOT UNDER BID ITEM "VALLEY GUTTER". MEASURE LENGTHS ALONG THE STRAIGHT FLOW LINE FROM EXPANSION JOINTS "A" AND "B" TO POINT "D" AND ON BOTH SIDES FROM EXPANSION JOINT "C" TO THE POINT "D". THE STREET SECTION SHALL BE MEASURED FROM POINT "D" TO POINT "D". IF P.C.C., THE STREET SECTION SHALL BE INCLUDED UNDER BID ITEM "VALLEY GUTTER". IF ASPHALT, THE STREET SECTION COST SHALL BE INCLUDED UNDER THE APPROPRIATE PAVING BID ITEM.

MUNICIPALITY

 OF ANCHORAGE

SCALE:
NTS
 APPROVED:
 REVISED:
10/07

TYPICAL SECTION VALLEY GUTTER

SECTION #
30.02
 DETAIL #
30-3

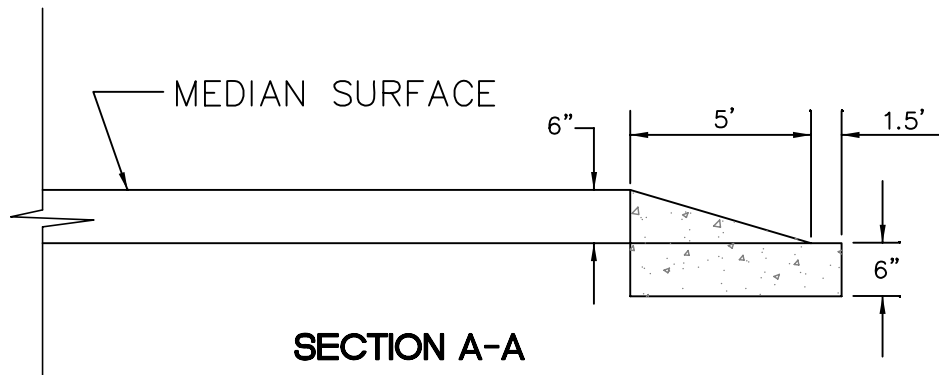
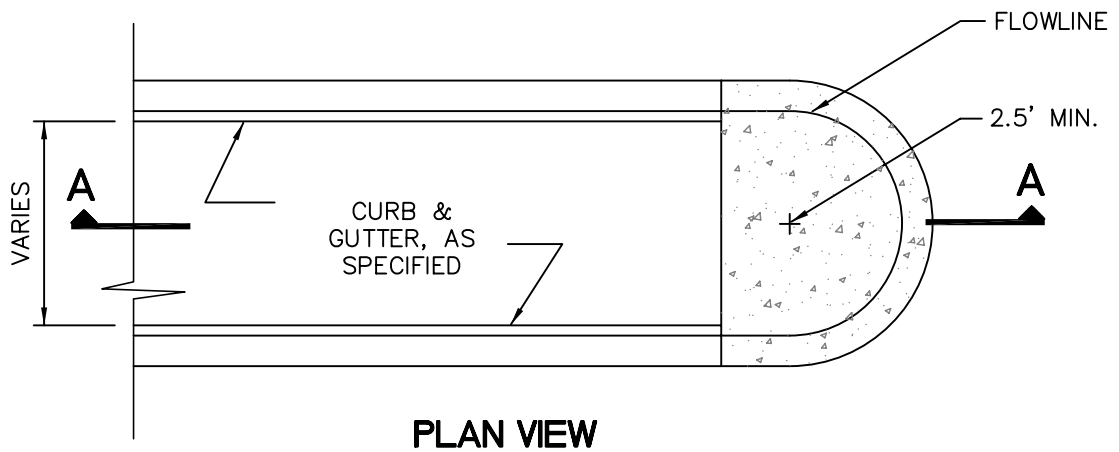

NOTE:

PAINT MEDIAN AND CURB NOSE WITH YELLOW TRAFFIC PAINT, THE PAINT SHALL BE CONSIDERED INCIDENTAL TO THE BID ITEM "CURB NOSE".

MUNICIPALITY



OF ANCHORAGE

SCALE:
NTS

APPROVED:

REVISED:
10/07

TYPICAL SECTION MEDIAN/CURB NOSE

SECTION #
30.02

DETAIL #
30-4

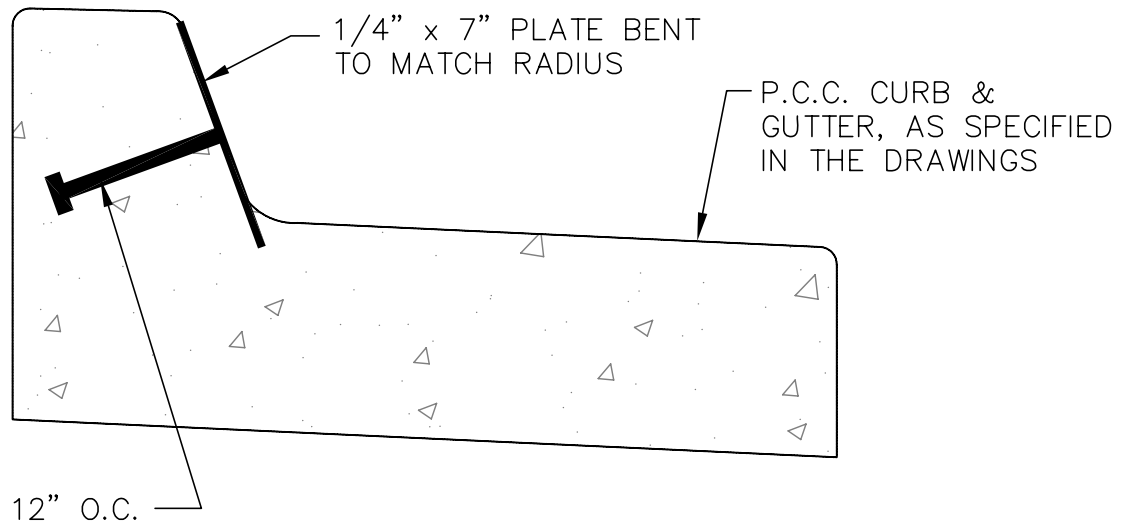

1/2"Ø STUDS @ 12" O.C.

NOTES:

1. BEND LEADING AND TRAILING EDGES 90° AND EMBED IN CONCRETE 1" MINIMUM.
2. STEEL CURB FACING SHALL BE INSTALLED ONLY IN LOCATIONS WHERE THERE IS A CURVILINEAR TRANSITION TO THE CURB FACE SUCH AS IN A CURB BULB OR TRANSIT PULL-OUT.

MUNICIPALITY



OF ANCHORAGE

SCALE:
NTS

APPROVED:

REVISED:
4/08

STEEL CURB FACING

SECTION #
30.02

DETAIL #
30-5

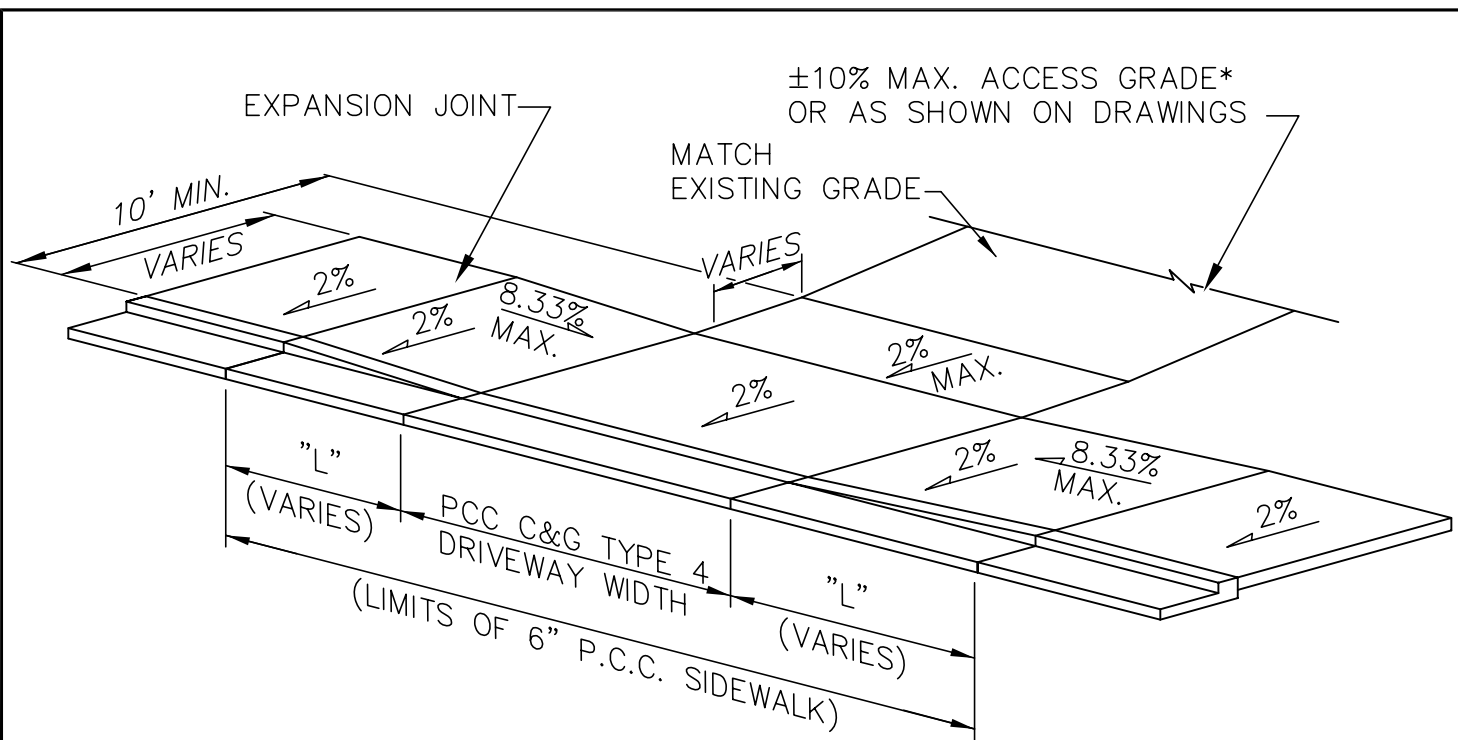

**TYPICAL DRIVEWAY ENTRANCE
(WITH ATTACHED SIDEWALK)**

DRIVEWAY RAMP RUNNING SLOPE TABLE		
STREET RUNNING SLOPE	MINIMUM UPHILL RAMP LENGTH "L"	MINIMUM DOWNHILL RAMP LENGTH "L"
0.0% TO 0.5%	6.0'	6.0'
> 0.5% TO 1.6%	7.0'	6.0'
> 1.6% TO 2.4%	8.0'	5.0'
> 2.4% TO 3.1%	9.0'	5.0'
> 3.1% TO 3.6%	10.0'	5.0'
> 3.6% TO 4.0%	11.0'	4.0'
> 4.0% TO 4.4%	12.0'	4.0'
> 4.4% TO 4.7%	13.0'	4.0'
> 4.7% TO 5.0%	14.0'	4.0'
> 5.0%	15.0'	4.0'

* MAXIMUM ALGEBRAIC DIFFERENCE IS 8% ON COMMERCIAL/INDUSTRIAL DRIVEWAYS.



SCALE:
NTS

APPROVED:

REVISED:
4/08

**DRIVEWAY CURB-CUT
WITH ATTACHED SIDEWALK**

SECTION #
30.03

DETAIL #
30-6

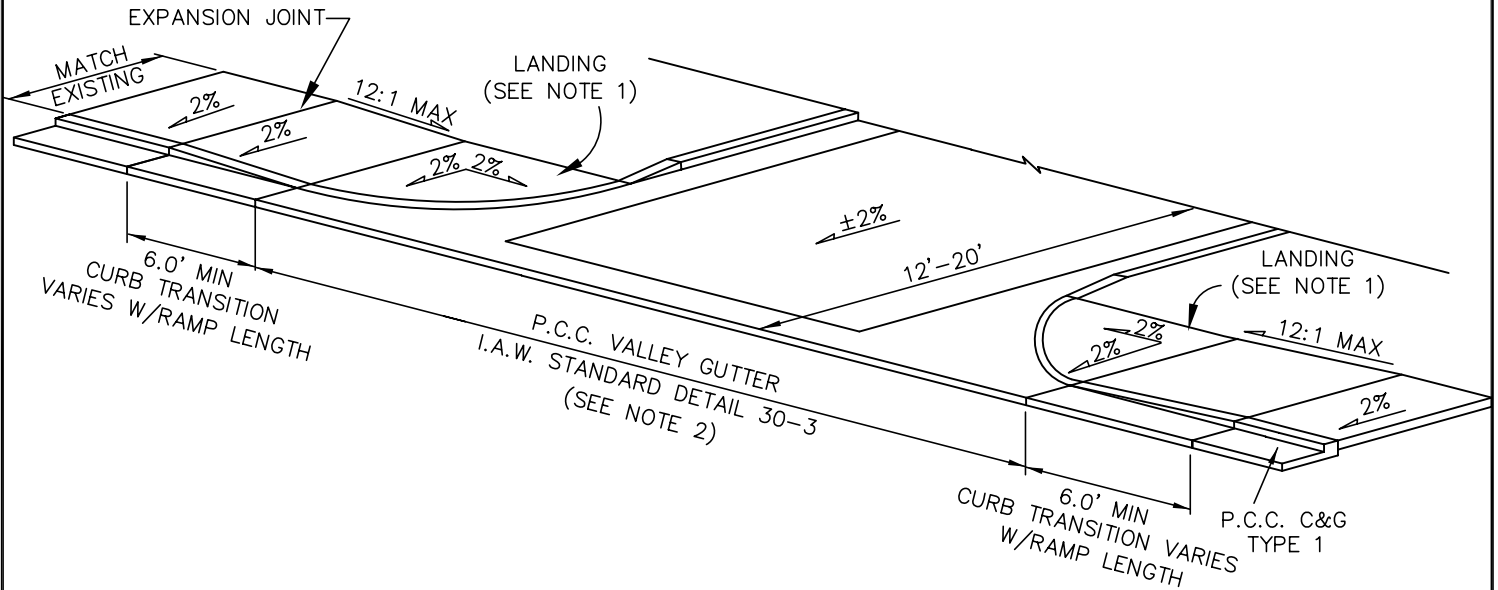

NOTES:

1. SIZE LANDING TO MEET ADA REQUIREMENTS.
2. P.C.C. VALLEY GUTTER TO BE CONSTRUCTED ON COMMERCIAL/INDUSTRIAL STREETS, ARTERIALS, AND COLLECTORS. ASPHALT CONCRETE SWALES TO BE CONSTRUCTED ON LOCAL OR RESIDENTIAL ROADWAYS. CONTRACTOR TO DEPRESS LIPS OF GUTTER TO ENSURE ADEQUATE DRAINAGE.

 <p>MUNICIPALITY OF ANCHORAGE</p>	<p>SCALE: NTS</p> <p>APPROVED:</p> <p>REVISED: 4/08</p>	<p>DRIVEWAY CURB RETURN WITH ATTACHED SIDEWALK</p>	<p>SECTION # 30.03</p> <p>DETAIL # 30-7</p>
--	---	---	---

REVISION: 12/09 CHANGED MIN RAMP WIDTH TO 5'; CHANGED RUNNING GRADE MIN TO CORRESPOND TO STD5

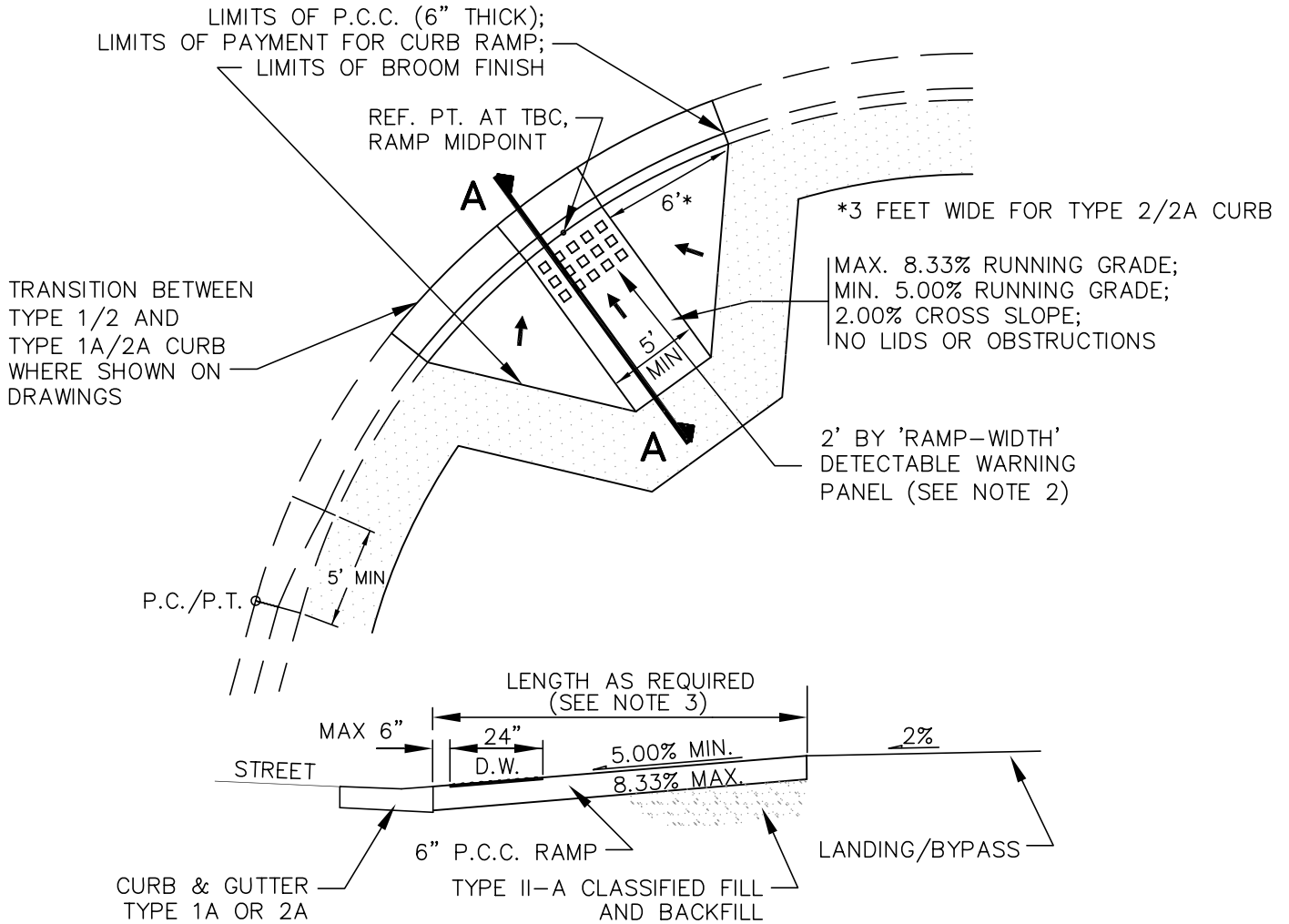

SECTION AA

NOTES:

1. CONSTRUCT PERPENDICULAR RAMPS AND FLARES WITH A BROOM FINISH PARALLEL TO THE CURB.
2. INSTALL DETECTABLE WARNING PANELS (D.W.) IN ACCORDANCE WITH MANUFACTURER'S RECOMMENDATIONS AND THE DRAWINGS. SET DETECTABLE WARNINGS SO THAT THE FIELD AREA AT THE BASE OF THE DOMES IS FLUSH WITH SURROUNDING CONCRETE. NO LIP IS ALLOWED AT THE EDGE OF THE DETECTABLE WARNINGS.
3. RAMP LENGTH REQUIRED FOR A TYPICAL SIDEWALK IS 8.0' FOR A TYPE 1/1A CURB, AND 4.0' FOR A TYPE 2/2A CURB. LENGTH VARIES FOR SIDEWALKS WITH DETACHED AND/OR INDEPENDENT GRADES. SEE DRAWINGS FOR NON-STANDARD RAMP LENGTHS.
4. TRIM OUTSIDE EDGES AND JOINTS OF RAMP AND FLARES WITH ONE-QUARTER INCH (1/4") RADIUS EDGING TOOL.
5. SEE DRAWINGS FOR REFERENCE POINT STATION AND OFFSET.
6. WHEN NO CONNECTING SIDEWALK, THE BY-PASS MUST CONTINUE AROUND THE RAMP BEFORE TERMINATING IN SIDE STREET.

MUNICIPALITY



OF ANCHORAGE

SCALE:
NTS

APPROVED:

REVISED:
12/09

PERPENDICULAR CURB RAMP

SECTION #
30.04

DETAIL #
30-8

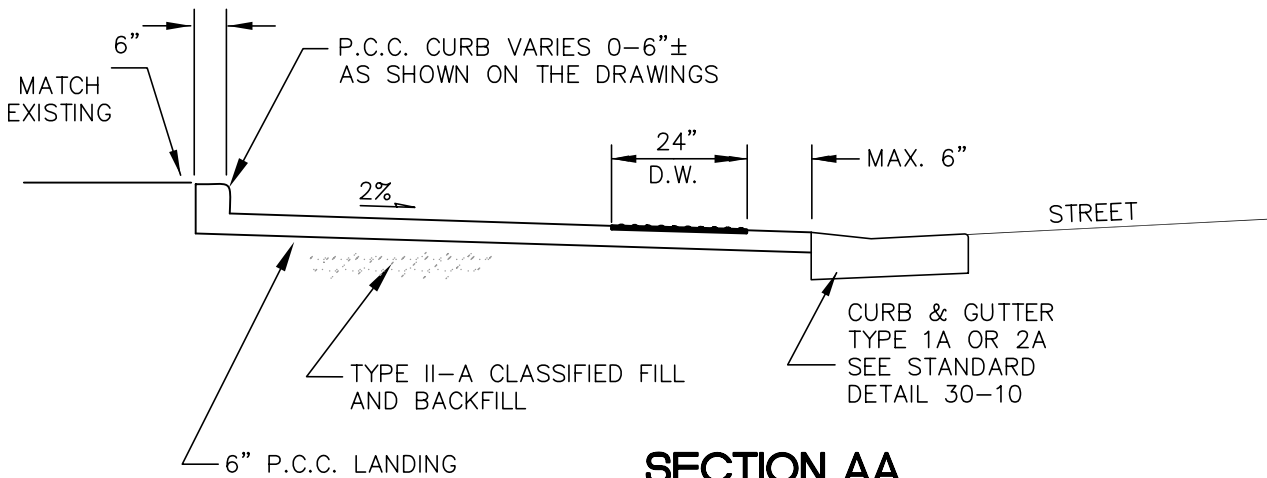
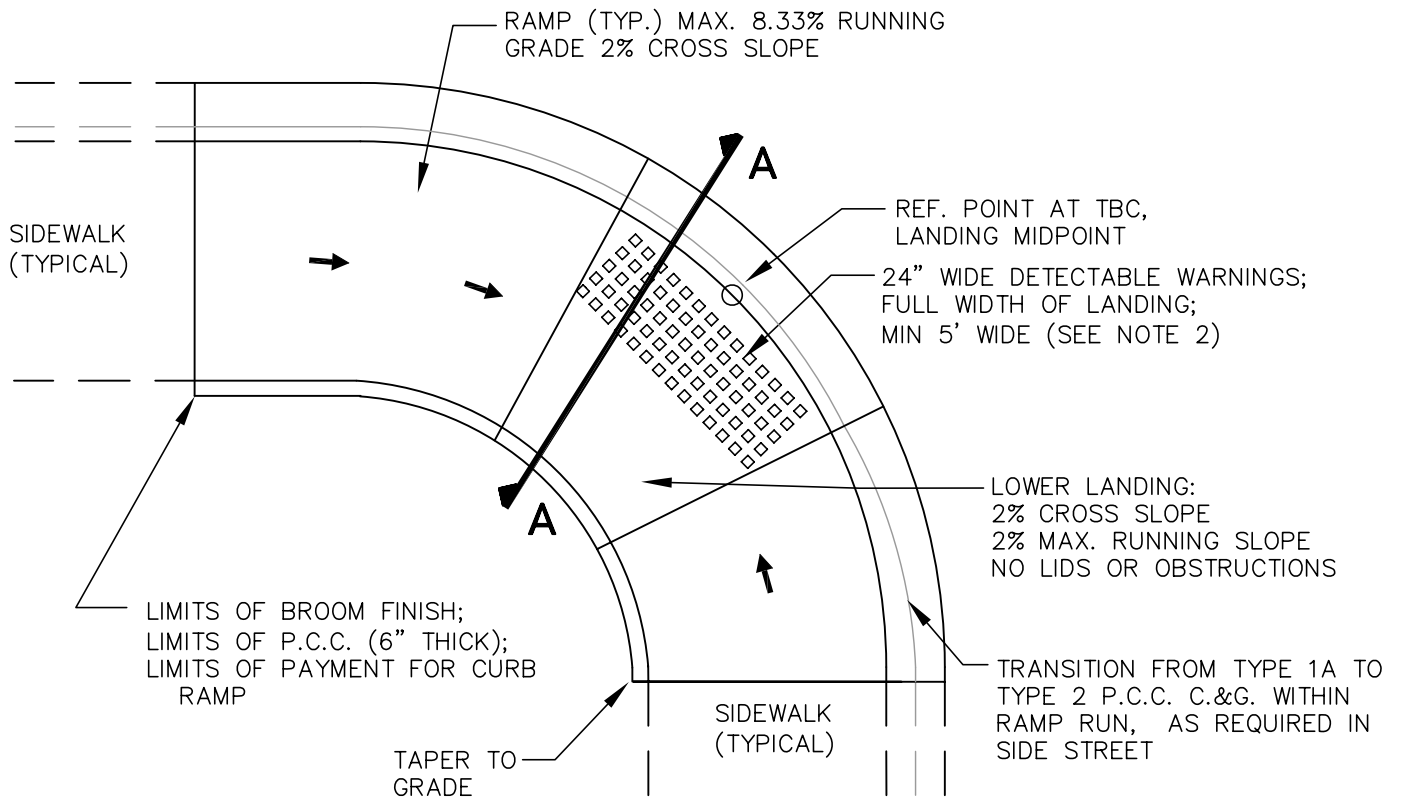

SECTION AA

NOTES:

1. RAMP LENGTHS AND REFERENCE POINT STATION AND OFFSET SHALL BE AS SHOWN ON DRAWINGS.
2. INSTALL DETECTABLE WARNINGS (D.W.) IN ACCORDANCE WITH MANUFACTURER'S RECOMMENDATIONS AND THESE DRAWINGS. SET DETECTABLE WARNINGS SO THAT THE FIELD AREA AT THE BASE OF THE DOMES IS FLUSH WITH THE SURROUNDING CONCRETE. NO LIP IS ALLOWED AT THE EDGE OF THE DETECTABLE WARNINGS.
3. CONSTRUCT RAMPS AND LANDINGS WITH A BROOM FINISH PERPENDICULAR TO CURB.

REVISION: 12/09 CHANGED MINIMUM RAMP WIDTH TO 5'

MUNICIPALITY

 OF ANCHORAGE

SCALE:
NTS
 APPROVED:
 REVISED:
12/09

PARALLEL CURB RAMP

SECTION #
30.04
 DETAIL #
30-9

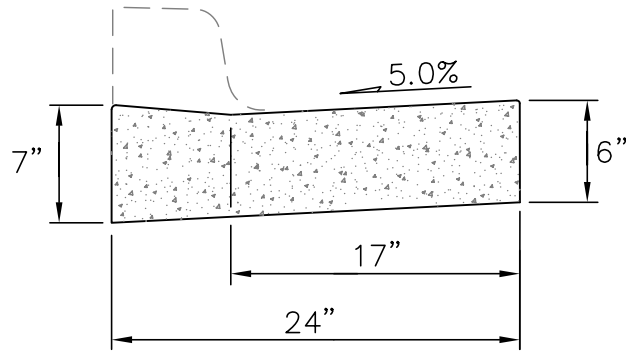

P.C.C. CURB AND GUTTER
TYPE 1A
 (FOR USE IN CURB RAMPS)

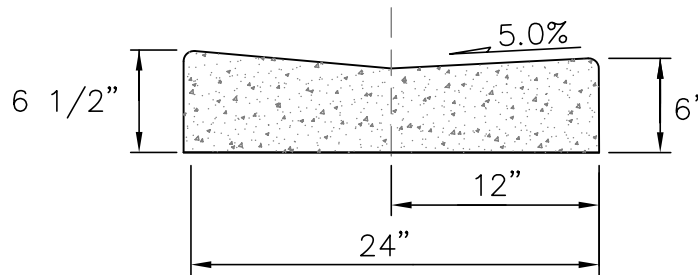

P.C.C. CURB AND GUTTER
TYPE 2A
 (FOR USE IN CURB RAMPS)

NOTES:

1. TRANSITION CURBS TO MAINTAIN CONSTANT FLOWLINE ACROSS CURB RAMP AND AROUND CURB RETURN PER THE DRAWINGS.

MUNICIPALITY



OF ANCHORAGE

SCALE:
 NTS

APPROVED:

REVISED:
 8/08

ACCESSIBLE (TYPE 1A/2A)
CURB AND GUTTER
SECTIONS

SECTION #
 30.04

DETAIL #
 30-10

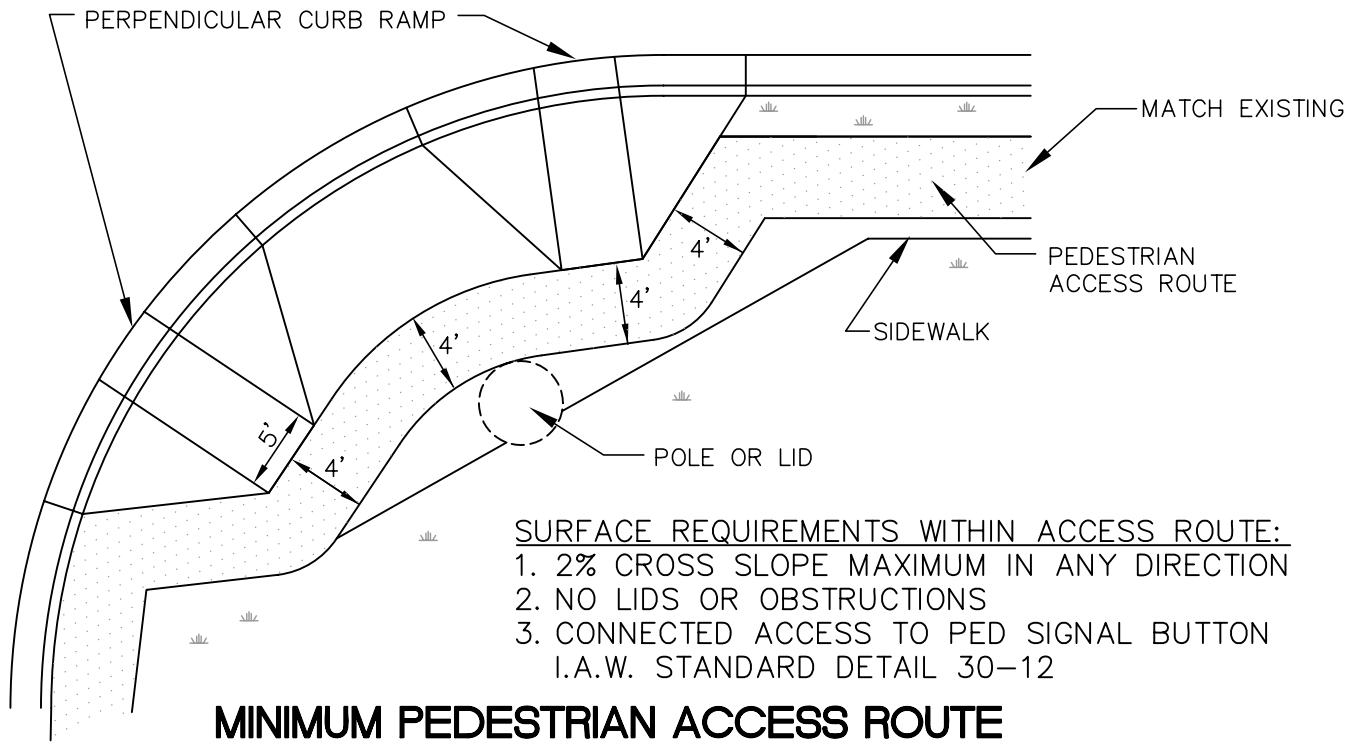

- SURFACE REQUIREMENTS WITHIN ACCESS ROUTE:
1. 2% CROSS SLOPE MAXIMUM IN ANY DIRECTION
 2. NO LIDS OR OBSTRUCTIONS
 3. CONNECTED ACCESS TO PED SIGNAL BUTTON
I.A.W. STANDARD DETAIL 30-12

**MINIMUM PEDESTRIAN ACCESS ROUTE
AROUND PERPENDICULAR CURB RAMPS**

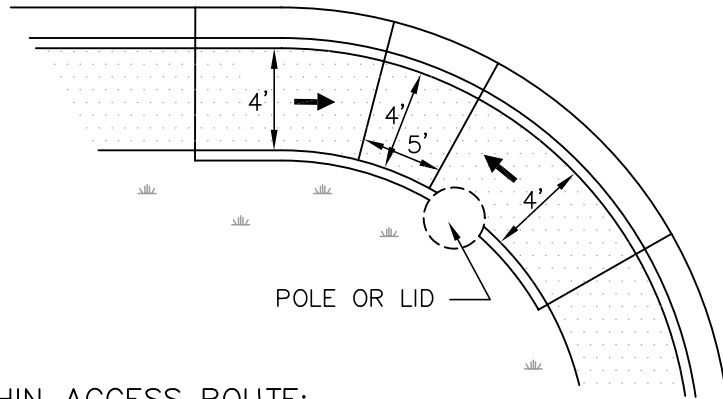

- SURFACE REQUIREMENTS WITHIN ACCESS ROUTE:
1. 2% CROSS SLOPE MAXIMUM IN ANY DIRECTION
 2. NO LIDS OR OBSTRUCTIONS
 3. CONNECTED ACCESS TO PED SIGNAL BUTTON
I.A.W. STANDARD DETAIL 30-12

**MINIMUM PEDESTRIAN ACCESS ROUTE
THROUGH PARALLEL RAMPS**

REVISION: 12/09 CHANGED MINIMUM RAMP WIDTH TO 5'

MUNICIPALITY



OF ANCHORAGE

SCALE:
NTS

APPROVED:

REVISED:
12/09

CURB RAMP CLEARANCES

SECTION #
30.04

DETAIL #
30-11

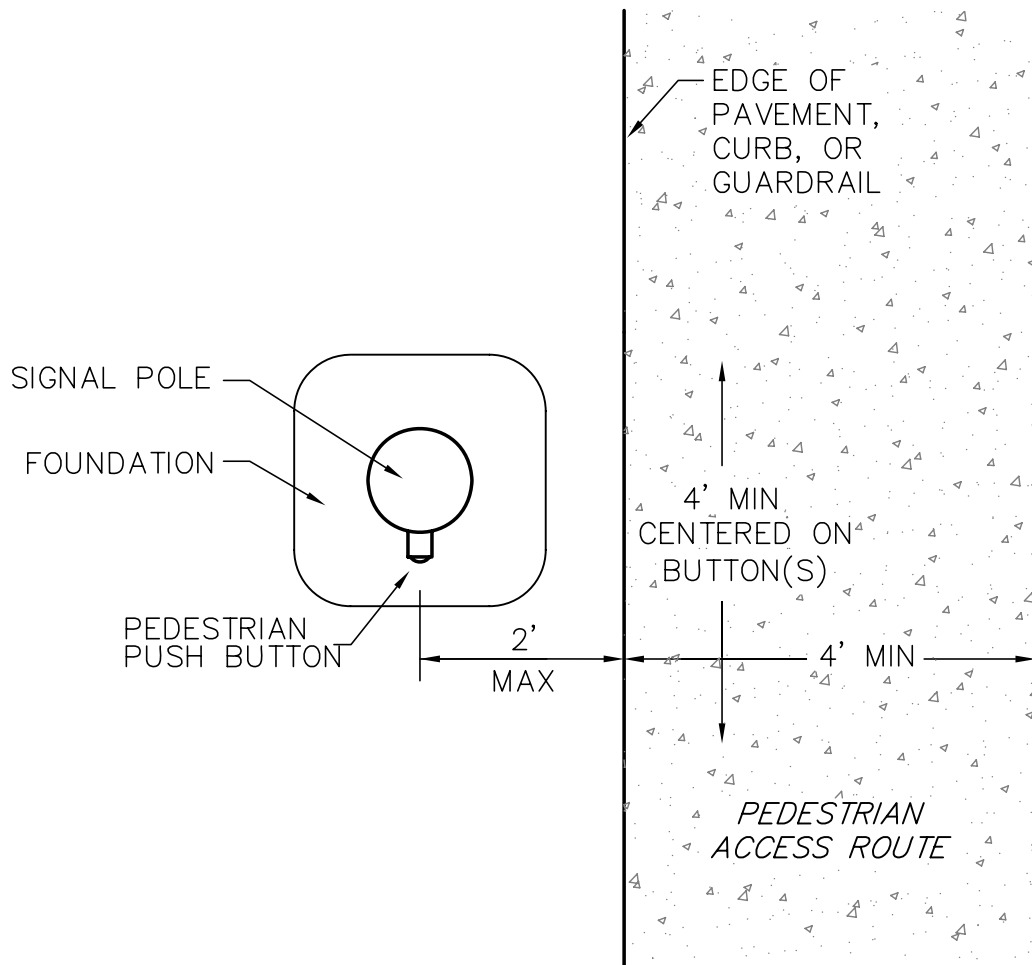

ACCESSIBLE PEDESTRIAN PUSH BUTTON APPROACH

NOTES:

1. PEDESTRIAN PUSH BUTTONS SHALL HAVE AN ACCESSIBLE APPROACH AS SHOWN.
2. APPROACH AREA SHALL JOIN OR OVERLAP THE MAIN SIDEWALK/PATHWAY, AND SHALL BE SURFACED WITH THE SAME MATERIAL.
3. APPROACH SHALL NOT EXCEED 2% SLOPE IN ANY DIRECTION.
4. APPROACH SHALL BE FREE FROM LIDS, OBSTRUCTIONS, AND LIPS.

MUNICIPALITY



OF ANCHORAGE

SCALE:
NTS

APPROVED:

REVISED:
8/08

PEDESTRIAN PUSH BUTTON ACCESS

SECTION #
30.04

DETAIL #
30-12

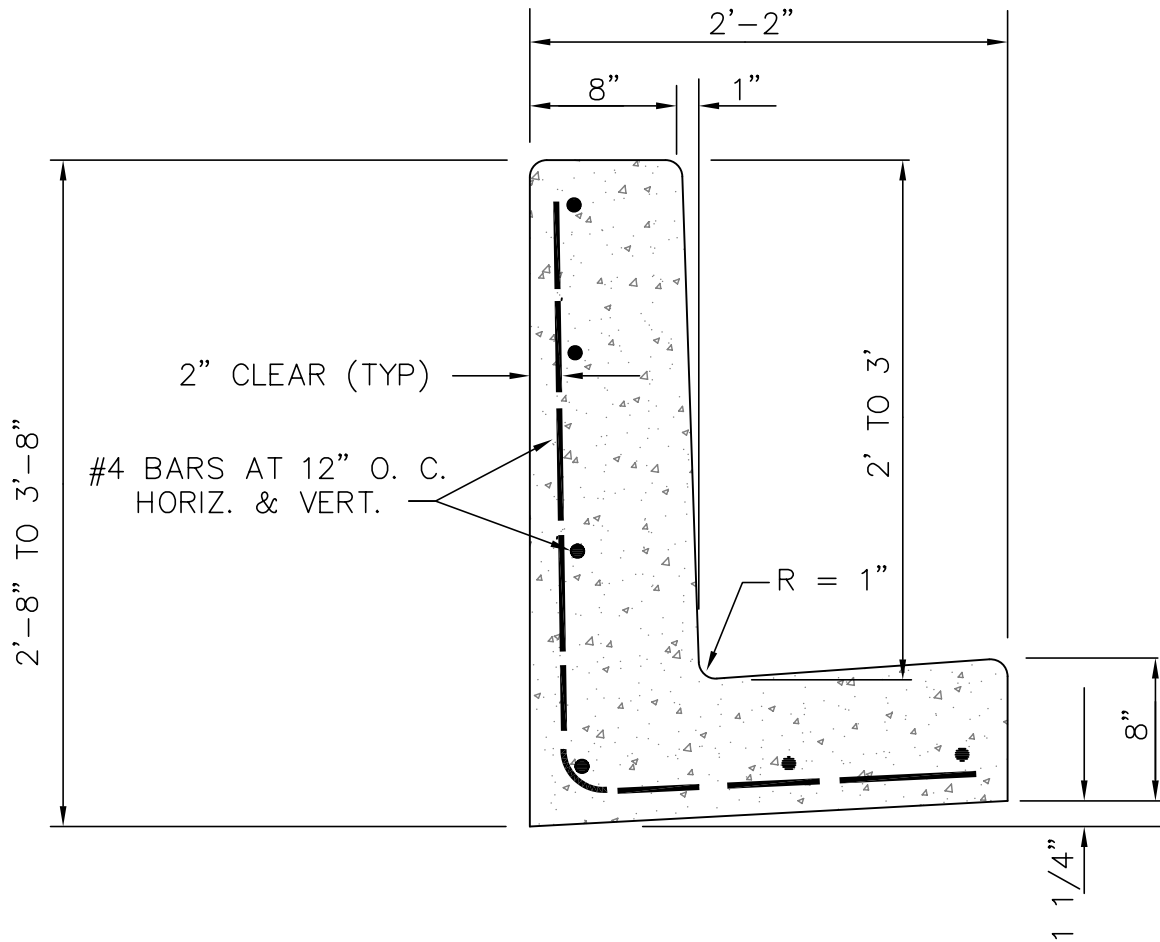

NOTE:

PROVIDE 3/4" X 3/4" CHAMFERED CORNERS AT ALL OUTSIDE EDGES.

MUNICIPALITY



OF ANCHORAGE

SCALE:
NTS

APPROVED:

REVISED:
8/08

CURB TYPE RETAINING WALL 2' TO 3'

SECTION #
30.05

DETAIL #
30-13

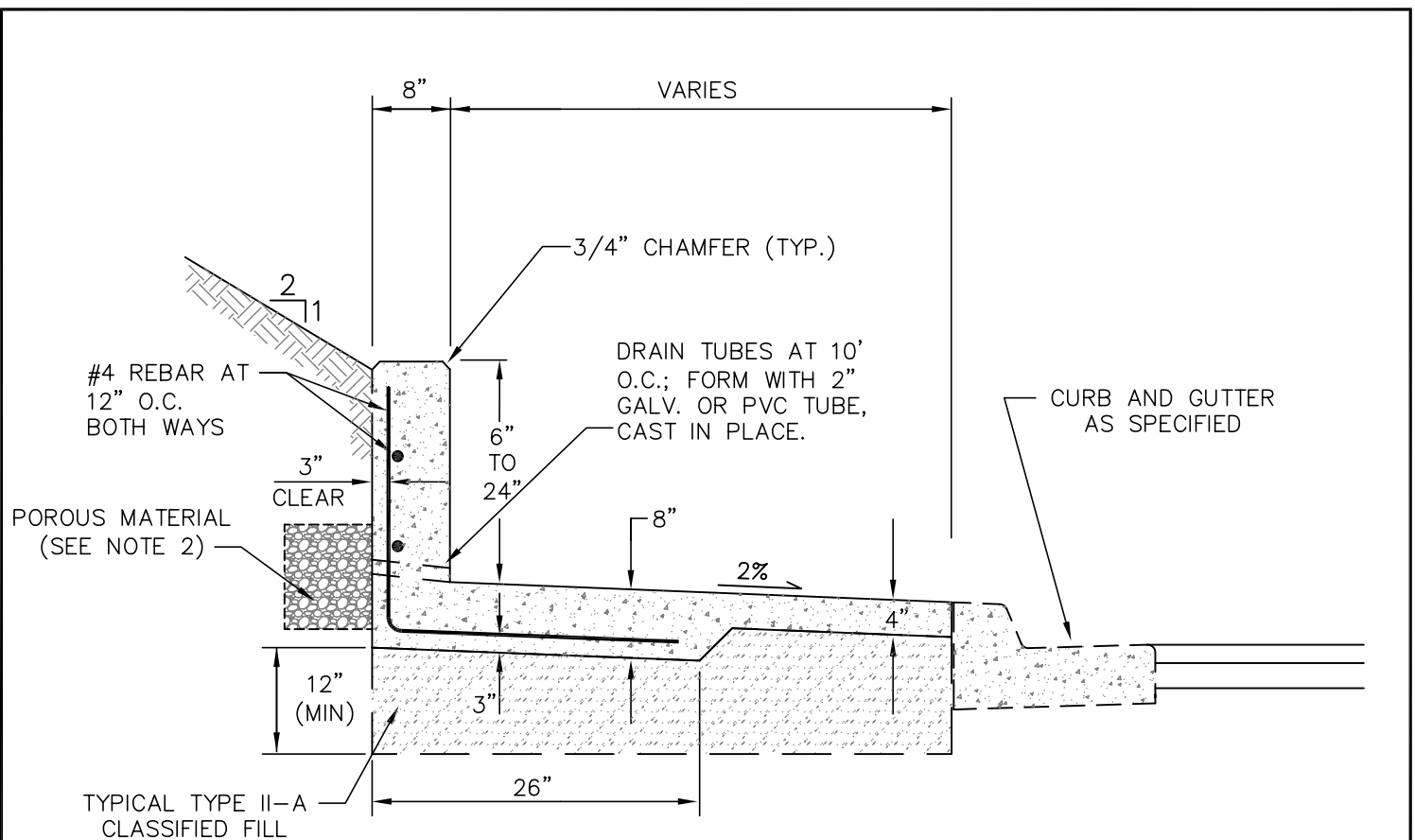

SIDEWALK RETAINING WALL

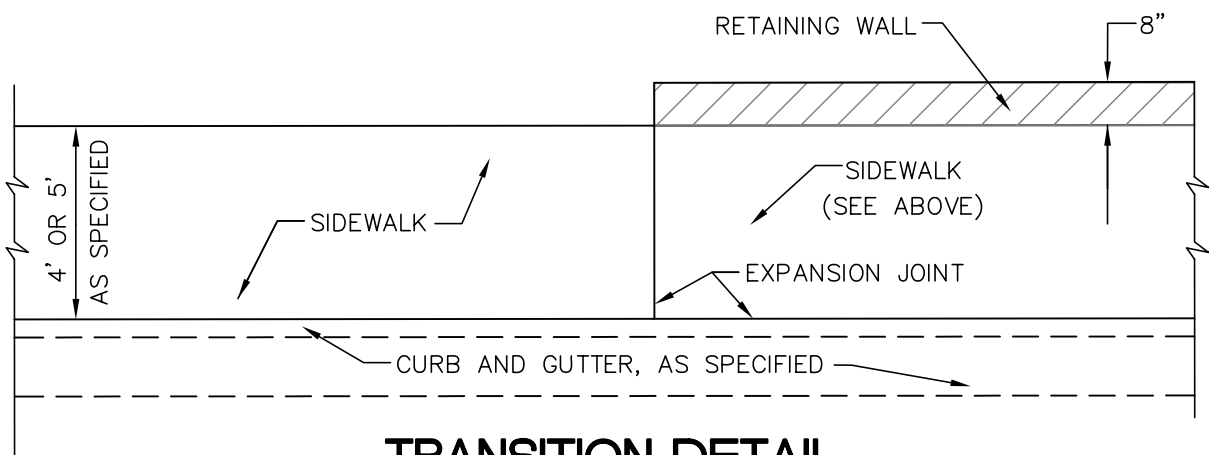

**TRANSITION DETAIL
(PLAN VIEW)**

NOTES:

1. STANDARD CURB AND GUTTER SECTION NOT INCLUDED IN UNIT BID PRICE FOR RETAINING WALL.
2. PLACE ONE CUBIC FOOT OF POROUS BACKFILL MATERIAL AROUND WEEP HOLE AS SHOWN.
3. PROVIDE 3/4" X 3/4" CHAMFERED CORNERS AT ALL OUTSIDE EDGES.

 <p>MUNICIPALITY OF ANCHORAGE</p>	<p>SCALE: NTS</p> <p>APPROVED:</p> <p>REVISED: 8/08</p>	<p>SIDEWALK RETAINING WALL</p> <p>6" TO 24"</p>	<p>SECTION # 30.05</p> <p>DETAIL # 30-14</p>
--	---	---	--

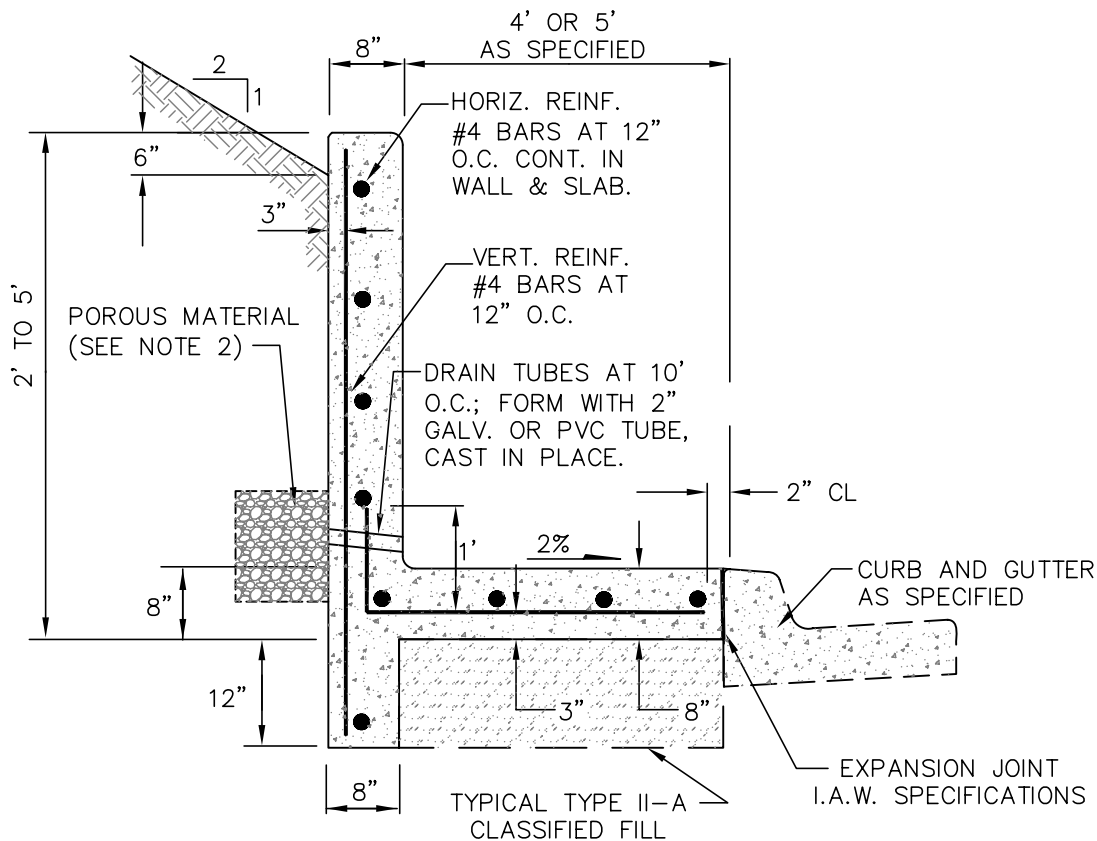

SIDEWALK RETAINING WALL

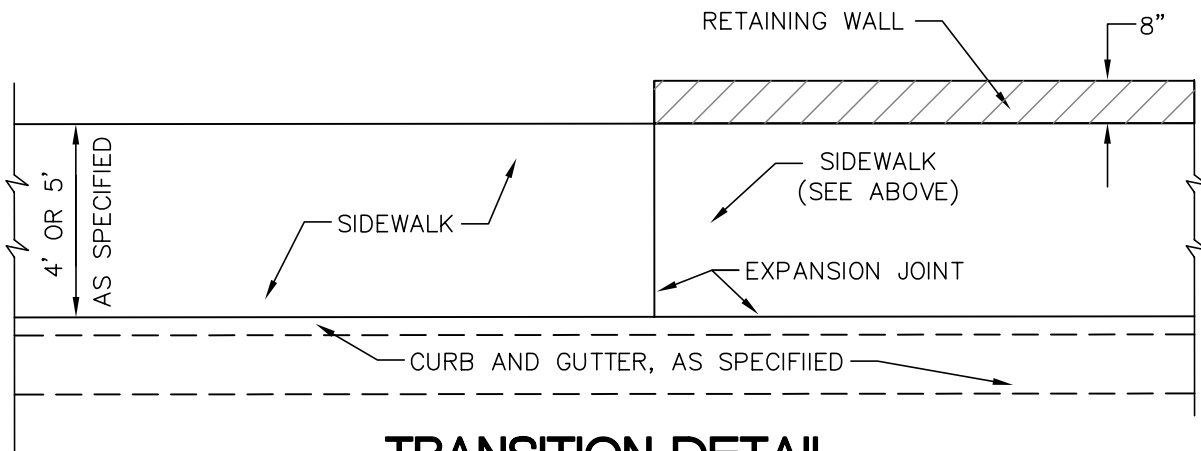

TRANSITION DETAIL (PLAN VIEW)

NOTES:

1. STANDARD CURB AND GUTTER SECTION NOT INCLUDED IN UNIT BID PRICE FOR RETAINING WALL.
2. PLACE ONE CUBIC FOOT OF POROUS BACKFILL MATERIAL AROUND WEEP HOLE AS SHOWN.
3. PROVIDE 3/4" X 3/4" CHAMFERED CORNERS AT ALL OUTSIDE EDGES.

MUNICIPALITY



OF ANCHORAGE

SCALE:
NTS

APPROVED:

REVISED:
8/08

SIDEWALK RETAINING WALL

2' TO 5'

SECTION #
30.05

DETAIL #
30-15

