

# Municipality of Anchorage Child Care Licensing Program

## Introduction to the Provisional Child Care Licensing Process

(Keep this document for your business records)

This packet is designed to provide explanation and instructions to assist you in completing the requirements for a Provisional Child Care License. Child care licensing requirements are based on Municipality of Anchorage (MOA) code and State of Alaska (SOA) child care licensing statutes and regulations.

The code, statutes, and regulations are located on the MOA Child Care Licensing (CCL) Program and the SOA Child Care Program Office (CCPO) websites at:

MOA/CCL: <https://www.muni.org/Departments/health/Childcare/Pages/default.aspx>

SOA/CCPO: <http://www.hss.state.ak.us/dpa/programs/ccare>

Applicants are expected to read the child care licensing code, statutes, and regulations thoroughly prior to licensure. Once licensed, a child care facility is required to comply with each code, statute, and regulation.

If you have questions at any time during your review of the child care licensing statutes and regulations or the licensing process, please contact the CCL Program at 907-343-4758 or email [hhscl@muni.org](mailto:hhscl@muni.org).

The requirements and forms listed in this packet are all components of the licensing process for a Provisional Child Care License. Each form must be legibly completed and submitted with the required supporting documentation to the CCL Program to complete the licensing requirements for a Provisional Child Care License. Additional forms and resources are also available on the CCL website at:

<https://www.muni.org/Departments/health/DirectServices/Pages/Child.aspx>

**Please Note:** Application packets submitted with incomplete forms or required forms missing will be considered incomplete and those incomplete or missing forms/items will be returned to the applicant delaying the licensing process.

## Provisional Child Care Licensing Application Requirements

A complete application packet for a Provisional Child Care License must be submitted on forms supplied by the department as listed below or on the application which include any additional supplemental documentation and action required, as applicable.

### 1. APPLICATION FOR PROVISIONAL CHILD CARE LICENSE

The *Application for Provisional Child Care License CC52* form provides the CCL Program with information the department needs to determine if the applicant/administrator meets regulatory requirements to operate a licensed child care facility. The application consists of several sections which all need to be completed, if applicable to your facility. Note: In a home or group home the applicant (owner) or the administrator must reside in the residence.

#### **Plan review fee:**

MOA applicants only: A fee is required with the application for a provisional child care license.

1 to 8 children	\$30.00
9 to 20 children	\$30.00
21 to 80 children	\$65.00
81 plus children	\$130.00

### 2. VALID CRIMINAL HISTORY CHECK

A valid criminal history check is required for all individuals described in 7 AAC 10.910(a) who are associated with a child care facility and who are 16 years of age or older. applicants/individuals are required to submit an application to the Alaska Background Check Program (BCP) and receive a valid criminal history check through the New Alaska Background Check System (NABCS) prior to having contact with children.

In order to obtain a criminal history check, you must have a myAlaska username and password as well as a valid email address. If you need to establish a myAlaska account, please visit: <https://my.alaska.gov> .

Once an application packet for a Provisional Child Care License is received by the CCL Program, additional instructions on how to obtain a valid criminal history check will be provided.

### 3. PEDIATRIC CPR AND FIRST AID

Regulations require all caregivers to have pediatric cardiopulmonary resuscitation (CPR) and First Aid certifications. A copy of both sides of the valid certifications must be submitted as part of your application packet.

### 4. STATE OF ALASKA BUSINESS LICENSE

The State of Alaska requires all businesses to obtain a State of Alaska Business License prior to operating. To apply on-line for a State of Alaska Business License to operate as a child care facility, visit: <https://www.commerce.alaska.gov/web/cbpl/BusinessLicensing.aspx>. When applying for a business license to provide child care services, the primary or secondary line of

Funding through the State of Alaska, Department of Health and Social Services, Division of Public Assistance

business must be **62-Health Care and Social Assistance**, and the primary or secondary Northern America Industry Classification System (NAICS) code to be used is **624410 Child Day Care Services**. A copy of your State of Alaska Business License must be submitted as part of your application packet.

## 5. PLAN OF OPERATION

Child care licensing regulations require all licensed child care facilities to have a Plan of Operation. The following are required items that must be included in a child care facility's Plan of Operation and submitted with the application packet.

### A. Organization Chart and Staffing Chart:

An organization chart is a graphic outline of the organizational layout of a licensed child care facility with more than one position, which includes the hierarchy of each position represented in the structure of the facility. The staffing chart lists every position and if known at the time of application, the staff member associated with each position, including: the administrator, child care associates, caregivers, substitute caregiver, cooks, etc. The information required in a staffing chart could be submitted on a separate document or included in the organizational chart.

For a child care home with only one position, an organization chart and staffing chart are not required; however, the facility's parent policies must include information regarding the use of substitutes and/or the procedures for closing the facility when the administrator or administrator designee is unavailable.

### B. Facility Policies and Procedures, Plans, and Rules:

A licensed child care facility is required to adopt procedures, program descriptions, materials and forms into a policies and procedures manual and make it available to the Department, all employees, families enrolled in the facility, and other individuals associated with the facility. Your facility policies and procedures manual must include the following:

#### **Parent Policies:**

A licensed child care facility is required to provide parents with written information regarding their policies on enrollment and fees, typical daily schedules of activities, parent visiting and access, plan of supervision, and additional requirements as applicable. Enclosed is a *Child Care Facility Parent Policies Checklist CC77* outlining the information that must be provided in writing to parents at or before a child's admission. This checklist is enclosed to assist you in developing parent policies for your facility and each requirement must be marked off and a page number listed indicating where in the policies the information can be found.

**Please Note:** The *Parent's Guide to Licensed Child Care CC61* is included in this packet to provide to parents along with the Child Care Facility Parent Policies.

#### **Plan of Supervision:**

A licensed child care facility is required to ensure children are supervised at all times, including when children are indoors, outdoors, when participating in activities away from

Funding through the State of Alaska, Department of Health and Social Services, Division of Public Assistance

the facility, naptime, and during transportation. The child care facility's policies must include the following: group size; child-to-caregiver ratios; and how children will be supervised at all times, including during periods of rest. Your Plan of Supervision may be included in your Child Care Facility Parent Policies.

### **Personnel Policies:**

A licensed child care facility is required to create and maintain personnel policies that include, but are not limited to, the following: a job description for each position; qualifications required for each position; and a description of the facility's procedure for completing annual evaluations. The *Child Care Facility Personnel Policies Checklist CC60* is enclosed to assist you in developing personnel policies for your facility and should be cross referenced to ensure at minimum all "required" items listed are included and submitted as part of your application packet.

For a child care home, personnel policies are required only if the facility employs a substitute caregiver (Administrator Designee) or other qualified caregiver.

### **Child Care Facility Staffing Plan:**

The *Child Care Facility Staffing Plan CC71* must include each caregiver's position and their daily schedule and reflect the facility's daily children's attendance to ensure appropriate child-to-caregiver ratios are maintained at all times.

For a child care home, the *Child Care Facility Staffing Plan CC71* is required only if the facility employs a substitute caregiver (Administrator Designee) or other qualified caregiver.

### **Disaster Preparedness and Emergency Evacuation Plan:**

A licensed child care facility is required to create a disaster preparedness and emergency evacuation plan and submit it to the Department. The *Get Out Alive! Disaster Preparedness and Emergency Evacuation Plan CC67* has been provided for your convenience to document your facility's emergency evacuation plan or to use as a guideline for developing your own plan that meets licensing requirements.

**Please Note:** The *First Aid and Disaster Kit Checklist CC62* is included in this packet to assist you in ensuring your kits are complete.

### **Other Plans and Rules:**

A licensed child care facility must submit any other plans or rules they have in addition to their policies and procedures and the required plans listed above, related to operating their facility. Examples may include but are not limited to, plan to address behavioral challenges; plan of care for children identified with special needs; plan for shared use spaces; and alternate outdoor recreation spaces.

**MOA applicants only:** For centers, submit a copy of the site plan and building plan. The site plan must include a new facility request for Land Use Review and must provide an as-built survey or an approved site plan identifying all parking and ADA accessible spaces. The as-built survey shows the building's footprint and its distance from the property lines – it may or may not show parking spaces. The site plan shows a less detailed site layout of parking lots, landscaping, outdoor play areas, etc. These documents may be available in your

Funding through the State of Alaska, Department of Health and Social Services, Division of Public Assistance

administrative files, or through the Municipal Building Safety permitting office (907-343-8211). Please list any recent building permits for the property, including a change-of-use. Provide copy of your conditional use permit where applicable. If you have a business card, please include this with your site plan.

**Please Note:** The *Plan for Shared Use of a Child Care Facility CC73* is included in this packet for you to complete if applicable to your facility.

Once your complete application packet for a provisional child care license is received by the CCL Program, the following additional requirements will determine if your facility meets all of the regulatory health and safety requirements for licensure. Once these additional requirements are completed a Provisional Child Care License may be issued.

### **APPROVAL BY STATE OR LOCAL FIRE MARSHAL**

**Fire Inspection Report:** Licensed child care facilities caring for six or more children must have an approval from their local or State of Alaska Fire Marshal's office depending on jurisdiction. Fire approval is not needed to be licensed for five or fewer children, unless required by a municipality to which the State Fire Marshal has deferred building fire safety inspection and enforcement activities under 13 AAC 50.075(c). A child care facility applying to operate any hours after 10:00pm or before 6:00am, or 24 hours a day will also need approval from their local or State Fire Marshal's office prior to a nighttime care specialization being approved by the department. After receipt of a complete application packet for a Provisional Child Care license, your Child Care Licensing Specialist will request the fire inspection from the appropriate Fire Marshal's office by submitting a *Fire Prevention Review of Application* request form. For applicants outside of Anchorage (Eagle River, Chugiak, Peters Creek, Eklutna, Indian, or Girdwood) the child care licensing specialist will provide you with contact information for the appropriate Fire Marshal's office, so you can contact them, as applicable to your facility's location. It is the responsibility of the applicant to ensure payment of any applicable fees. MOA applicants refer to Resource Handout.

### **APPROVAL BY ENVIRONMENTAL HEALTH FOOD SAFETY & SANITATION (FS&S) PROGRAM**

**Food Service (child care centers only):** Licensed child care centers serving or preparing food may be required to obtain a *Food Service Permit*. It is your responsibility to contact FS&S at 907-343-4200 or email [FoodWorkerCard@muni.org](mailto:FoodWorkerCard@muni.org) to begin the plan review process to obtain a food permit. Once the plan review process is complete and a food permit is issued, your Child Care Licensing Specialist will submit a request to the FS&S office requesting approval to operate. FS&S will contact you regarding any forms that may need to be completed, any additional required documentation to submit, notify you of any associated fees (if applicable), and to schedule an on-site inspection. MOA applicants refer to Resource Handout.

**Well Water (all facilities):** If your facility has a well water system your water must be tested for Nitrates and Coliform and approved by a DEC authorized water testing laboratory. For a list of authorized water testing laboratories visit: <https://dec.alaska.gov/eh/dw/dwp/private-wells/> A copy of the approved water test must be submitted as part of your application packet and annually thereafter.

**Septic System (all facilities):** If your facility has a septic system it must meet the requirements of 7 AAC 10.1030 Toilet facilities, sinks, showers, and bathing, and comply with wastewater disposal

regulations 18 AAC 72. For more information visit:

<https://dec.alaska.gov/water/wastewater/engineering/> or contact the Alaska Division of Water at (907) 465-5180 or 1 (800) 770-8973. A copy of the approval or installation authorization received from DEC must be submitted as part of your application packet.

### **APPROVAL BY LOCAL CITY PLANNING AND/OR ZONING OFFICE(S)**

Licensed child care facilities may be required to obtain specific approval or permits from their local city and/or zoning office(s) to operate a licensed child care facility in their community. It is your responsibility to contact your local city and/or zoning office(s) to determine if specific approval or permits are required and to take action as necessary to comply with the requirement(s). A copy of the approvals(s) or permits(s) must be submitted as part of your application packet. MOA applicants refer to Resource Handout.

### **PROVISIONAL CHILD CARE LICENSING ORIENTATION**

The Provisional Child Care Licensing Orientation involves a thorough review of the child care licensing code, statutes, and regulations with the facility's Administrator, and if applicable, a representative of the facility's Governing Body. During this orientation the Administrator and /or board representative will have the opportunity to meet one-on-one with a Child Care Licensing Specialist and have any questions answered prior to licensure.

The Provisional Child Care Licensing Orientation will be completed with the Child Care Licensing Specialist at the facility during the scheduled on-site inspection appointment. Please plan at least three to five hours to complete both the Provisional Child Care Licensing Orientation and the on-site inspection during the facility visit. The amount of time necessary for the scheduled appointment will vary based upon the facility type and questions posed by the Administrator and/or board representative.

### **ON-SITE INSPECTION**

The on-site inspection involves a thorough examination and evaluation to ensure the facility meets the regulatory health and safety requirements of licensure. Prior to the inspection, you will be provided with a copy of the *Child Care Licensing Inspection Checklist and addendum* used during the inspection for your review and preparation. Please note these checklists are not at all inclusive of child care licensing codes, statutes, and regulations.

A Child Care Licensing Specialist will inspect the premises, regardless of where care is planned to occur. The inspection includes a walkthrough of the inside of the facility, the outside property, and an examination of any vehicles(s) used to transport children to ensure all areas meet child care licensing requirements. All areas not meeting regulatory requirements during the inspection will be reviewed and discussed, and you will have an opportunity to make changes necessary to bring the facility into full compliance prior to a Provisional Child Care License being issued.

The inspection involves, but is not limited to, evaluation of the following: the overall environment, equipment, supplies, materials, and age appropriate toys and books required to be available for children in care, hot water temperature measuring between 100 and 120 degrees Fahrenheit throughout the facility; drawers, cabinets, and closets in bedrooms, bathrooms and kitchens inspected for health and safety concerns; and measurements of the square footage in care areas inside and outside of the facility to ensure there is sufficient space appropriate for the number (capacity) of children for which the facility is applying to be licensed.

MOA applicants only: For home facilities, the administrator will have to attend a one day orientation prior to CCL scheduling the on-site inspection.

**LICENSE FEE**

MOA applicants only: A license fee is due before an on-site pre-licensing inspection is conducted. The fee depends on the licensed capacity approved by the CCL Program. You will receive an invoice at the time the Child Care Licensing Specialist schedules the on-site pre-licensing inspection.

1 to 8 children	\$50.00
9 to 20 children	\$125.00
21 to 80 children	\$250.00
81 plus children	\$375.00

**COMPREHENSIVE GENERAL LIABILITY INSURANCE (AMC 16.55.115C.1)**

MOA applicants only: A licensed child care facility is required to maintain comprehensive general liability insurance coverage at all times to include transportation coverage if applicable. Once the pre-licensing inspection is completed and the Child Care Licensing Specialist has determined the facility is eligible for a provisional child care license, you will be required to obtain insurance coverage in an amount not less than:

1. \$300,000 per occurrence, and \$300,000 aggregate, for a facility licensed for 5 or fewer children;
2. \$500,000 per occurrence, and \$500,000 aggregate, for a facility licensed for 6 through 8 children;
3. \$1,000,000 per occurrence, and \$1,000,000 aggregate, for a center licensed for 9 through 40 children; and
4. \$1,000,000 per occurrence, and \$2,000,000 aggregate, for a center licensed for 41 or more children.

The facility shall provide written proof of a policy required by AMC 16.55 with the initial application, whenever the policy is renewed, and when the facility’s license from the municipality is renewed.

**PROVISIONAL CHILD CARE LICENSE ISSUANCE**

Once you have met the requirements for licensure, a Provisional Child Care License will be issued for the child care facility with an effective date of the first day of the following month. A Provisional Child Care License is issued for a period of one year, during which time your facility will be monitored through announced and unannounced inspections and investigations (as applicable), to ensure compliance with child care licensing regulations and requirements. You must be able to demonstrate compliance with child care licensing codes, statutes, and regulations in order to remain licensed and be eligible to renew your license and receive a Biennial Child Care License.

**Please Note:** A licensed child care facility found out of compliance with child care licensing requirements may be subject to enforcement actions including but not limited to: specific conditions; fines, revocation; or non-renewal of licensure; and/or revocation of the ability to provide child care services in the State of Alaska.



**Municipality of Anchorage  
Child Care Licensing Program**

Office Use Only

**CHILD CARE HOME - EMERGENCY DESIGNEE FORM**

7 AAC 57.500(h) a child care home shall designate an adult who is known by the home caregiver to be of good character, and is available to assist in case of serious illness, accident, or other emergency. If this adult assists only in emergency situations for part of the day during the emergency, the caregiver qualifications set out in 7 AAC 57.310 and the ability to administer first aid and CPR in a child care facility do not apply to that individual.

Administrator Name: \_\_\_\_\_

Name of Facility: \_\_\_\_\_

Physical Address of Facility: \_\_\_\_\_

*I understand that any individual serving in the role of an emergency is not required to submit any documents for a background clearance; however, they must be an adult with a reputable character.*

*The emergency designee may only assist in an emergency situation for a part of the day during the emergency. By definition, an emergency is a serious illness, accident or other emergency.*

Name of Emergency Designee: \_\_\_\_\_

\_\_\_\_\_  
Signature of Administrator

\_\_\_\_\_  
Date

---

*For Emergency Designee*

- *I understand I must be a responsible individual of reputable character who exercises sound judgment and is truthful and honest.*
- *I understand that as an emergency designee I may only assist in an emergency situation for a part of the day, during the emergency. By definition, an emergency is a serious illness, accident or other emergency.*
- *I understand that an emergency is an unplanned event, serious illness, accident or other serious emergency situation.*
- *I also understand I must cooperate with licensing representatives and other agencies during any inspections or investigations.*

\_\_\_\_\_  
Signature of Emergency Designee

\_\_\_\_\_  
Date





**Municipality of Anchorage  
Child Care Licensing Program**

**DISASTER PREPAREDNESS AND EMERGENCY EVACUATION PLAN CHECKLIST**

**Facility Name:** \_\_\_\_\_

This checklist is used to ensure all required items are addressed in the facility's disaster preparedness plan as required by the *Get Out Alive! Disaster Preparedness and Emergency Evacuation Plan CC67* and regulations.

**REQUIRED:**

**7 AAC 10.1010(e)** An entity must have a disaster preparedness and emergency evacuation plan that includes the following:

- Pg. \_\_\_\_ Evacuation procedures that ensure complete evacuation of children in care within 150 seconds (2 ½ minutes). Plan must include evacuation drills for the following:
  - Complete detailed plan for children under 30 months of age (if applicable)
  - Complete detailed plan for children with limited mobility
  - Complete detailed plan for children who otherwise may need assistance including mentally, visually, or hearing impaired
- Pg. \_\_\_\_ Procedures facility will take during emergency situations or natural disasters to include: (if applicable to the facility's location)
  - Fire
  - Tsunami/flooding
  - Earthquake
  - Lock-down
  - Shelter-in-place
- Pg. \_\_\_\_ Relocation site
- Pg. \_\_\_\_ Plan to reunify children with parents in the event children are relocated due to an evacuation
- Pg. \_\_\_\_ Emergency evacuation drills
  - Conduct monthly emergency evacuation drills
  - Record monthly emergency evacuation drills
  - Participation of all caregivers who are on duty during the scheduled drill
- Pg. \_\_\_\_ Location of Disaster Preparedness kit
- Pg. \_\_\_\_ Location of First Aid kit
- Pg. \_\_\_\_ Location of second First Aid kit/abbreviated First Aid kit (if applicable)
- Pg. \_\_\_\_ Training of caregivers on the implementation of the *Disaster Preparedness and Emergency Evacuation Plan*
- Emergency Evacuation floor plan for each level of the facility which identifies the following:
  - Smoke detectors (**SD**) for each level and napping/sleeping room/s
  - Fire extinguishers (**FE**) for each level
  - Carbon monoxide (**CM**) detectors for each level
  - Escape routes from every room – homes, for each level, centers, include primary and secondary escape routes
  - Doors and windows clearly marked for each level
- Specified meeting place outside of the facility, describe meeting place, and mark the meeting place on the plan

**Note:** Additional information can be added at the discretion of the facility, such as: alternate location address and phone number, etc.



Municipality of Anchorage  
**CHILD CARE LICENSING PROGRAM**

Office Use Only
-----------------

**APPLICATION FOR PROVISIONAL CHILD CARE LICENSE**

**APPLICANT INFORMATION:** This person must be the owner of the child care facility, or if the business owner is a corporation, the president or registered agent according to the provider's State of Alaska Business License. This person may be different from the individual (administrator) who is responsible for maintaining compliance with child care licensing regulations and the day to day operations of the facility.

Name of Applicant (Owner): \_\_\_\_\_ Title: \_\_\_\_\_

Social Security Number: \_\_\_\_\_ DOB: \_\_\_\_\_

Mailing Address: \_\_\_\_\_  
(PO Box/Street) (City/State/Zip)

Phone Number: \_\_\_\_\_ Fax Number: \_\_\_\_\_

Email Address: \_\_\_\_\_ myAlaska Account User Name: \_\_\_\_\_

**PROPERTY/BUILDING OWNER INFORMATION:** If same as applicant, check the box below attesting there are no restrictions forbidding you to operate a child care business at the physical address of the facility noted in Facility Information section on next page. If different than applicant, each line in this section must be completed with the property owner's information and the property owner/manager must submit a signed and dated *Permission to Operate a Child Care Business CC72* form, as evidence of permission to operate a licensed child care facility on the premises.

I attest that the covenants, home owners' association bylaws, and other applicable neighborhood restrictions do not forbid operating a child care business at this address.

Name of Property Owner: \_\_\_\_\_ Title: \_\_\_\_\_

Mailing Address: \_\_\_\_\_  
(PO Box/Street) (City/State/Zip)

Phone Number: \_\_\_\_\_ Fax Number: \_\_\_\_\_

Email Address: \_\_\_\_\_

**FACILITY INFORMATION:** Select the form of organization and enter the name of your child care facility as listed on your State of Alaska Business License and any legal documents pertaining to your business. Research should be conducted prior to choosing the name of your facility to ensure the name chosen will not be confused with another facility.

- Business Corporation  C Corporation  Cooperative Corporation  Nonprofit Corporation
- Professional Corporation  Public Corporation  Religious Corporation  S Corporation
- General Partnership  Limited Liability Partnership  Limited Partnership  Limited Liability Company  Sole Proprietorship

Name of Facility: \_\_\_\_\_

Physical Address: \_\_\_\_\_  
(Street) (City/State/Zip)

Mailing Address: \_\_\_\_\_  
(PO Box/Street) (City/State/Zip)

Phone Number: \_\_\_\_\_ Fax Number: \_\_\_\_\_

Email Address: \_\_\_\_\_

**FACILITY TYPE:** Choose the type of child care facility license you are seeking. Approval of a facility type will be determined based on the requirements for the license type:

**Home:** Must have at least 1 caregiver/Administrator who is at least 21 years of age; allows up to 8 children usually in an occupied residence; meets child-to-caregiver ratios; and must have 35 square feet of usable indoor space and 75 square feet of outdoor recreation space per child.

**Center:** Must have a qualified Administrator, a Child Care Associate for each 30 children, meets child-to-caregiver ratios, allows 13 or more children, and must have 35 square feet of usable indoor space and 75 square feet of outdoor recreation space per child.

**Please note:** Additional requirements per facility type may be applicable prior to licensure, for example: meeting local city planning and/or zoning requirements, obtaining Fire Marshal approval (required if caring for six (6) or more children, by a municipality to which the state Fire Marshal has deferred building safety inspection and enforcement activities under 13 AAC 50.075(c), or if operating any hours after 10:00pm or before 6:00am, or 24 hours a day), and receiving approval or meeting the Department of Environmental Conservation (DEC) requirements, if applicable, for well water, and/or a septic system, or food service (MOA) Food Safety and Sanitations (FS&S) requirement if applicable. Occupancy rating, as applicable to facility type is based upon your local or State of Alaska Fire Marshal's office. The Fire Marshal's office will state whether or not you have to reside in the facility.

**NUMBER OF CHILDREN TO RECEIVE CARE (capacity):** Enter the number of children you want to be licensed for, in a home this will include your own children (including foster care children) younger than 13 years of age. For child care homes within the Municipality of Anchorage, no more than six (6) children in care at any time when initially licensed for the first twelve months. The capacity will be approved based on the child care facility meeting specific requirements by facility type, for example: required square footage per child, number of toilets and sinks in the facility, local city planning and/or zoning requirements, and local Fire Marshal approval.

**Requested Capacity:** \_\_\_\_\_

**AGE RANGE:** Enter the age range of the children you want to care for younger than 13 years of age, including your own children and foster care children if applicable.

**Requested Age Range:** \_\_\_\_\_ through \_\_\_\_\_

**HOURS OF OPERATION:** Enter the hours of the day (including a.m. or p.m.) and days of the week you want to operate your child care facility. Indicate "Closed" for days you are not in operation. If you are applying to operate any hours after 10:00 p.m. or before 6:00 a.m., or 24 hours a day, a **Request For Nighttime Care**

**Specialization CC53** form must be completed and submitted with the application, for department approval. An approval for nighttime care will also be necessary from your local Fire Marshal prior to a nighttime care specialization being approved by the department.

Sunday	Monday	Tuesday	Wednesday	Thursday	Friday	Saturday

**PROGRAM ACTIVITY SPECIALIZATION:** If you are applying for a program activity specialization for a moderate-risk activity such as: swimming, bicycle riding, etc., a **Request For Specialized Program Activity CC54** form must be completed and submitted with the application, for department approval.

Yes  No

If yes, I have attached a **Request For Specialized Program Activity CC54** form for each of the following moderate-risk activities included in my program:

---



---

**GOVERNING BODY INFORMATION:** Mark the box applicable to your facility. If your facility will be governed by a board of directors or other body, submit a **Governing Body Information CC55** form with the application.

Will your facility be governed by a board or other body?  Yes  No

**PERSONS LIVING ON THE PREMISES OF THE CHILD CARE FACILITY:** List ALL individuals living on the premises, starting with yourself (if applicable). A valid background check through the Alaska Background Check Program is required for all individuals associated with or living on the premises of the entity, who are 16 years of age and older, prior to licensure. Authority under: AMC 16.55.060, 7 AAC 57.010; 7 AAC 57.315; 7 AAC 10.900; 7 AAC 10.910.

	Name (first, last)	Title/Relationship	Date of Birth	Age	Driver's License #
1.	_____	_____	_____	_____	_____
2.	_____	_____	_____	_____	_____
3.	_____	_____	_____	_____	_____
4.	_____	_____	_____	_____	_____
5.	_____	_____	_____	_____	_____

**ADMINISTRATOR INFORMATION:** List the individual who is responsible for maintaining compliance with child care licensing regulations and the day to day operations of the facility. If the applicant and the administrator is the same person, please enter "same as applicant". An **Administrator Designation and Qualification Form CC56** and four **Child Care Facility Administrator Reference CC57** forms must be submitted with the application. CENTERS ONLY: In addition to the forms required for an administrator, one or more **Child Care Associate Designation and Qualification Form(s) CC58** and three **Child Care Facility Child Care Associate Reference CC59** forms must be submitted with the application for each Child Care Associate for every 30 children to receive care.

Name of Administrator: \_\_\_\_\_ Title: \_\_\_\_\_

Mailing Address: \_\_\_\_\_  
(PO Box/Street) (City/State/Zip)

Phone Number: \_\_\_\_\_ Fax Number: \_\_\_\_\_

Email Address: \_\_\_\_\_

**LICENSING HISTORY:** Indicate whether the applicant and/or administrator is currently or has previously been licensed, registered, certified, or approved to provide care for adults or children in any state. If yes is marked, please complete all of the boxes in this section. Include all types of care facilities, for example: assisted living, foster care, child care, etc.

**Applicant:** Are you currently or have you previously been licensed, registered, certified, or approved to provide care for children and/or adults?  Yes  No

If yes, complete the following:

Type of Facility	Name of Facility	Location of Facility (City and State)	Start and End Date of License

**Administrator:** Are you currently or have you previously been licensed, registered, certified, or approved to provide care for children and/or adults?  Yes  No

If yes, complete the following:

Type of Facility	Name of Facility	Location of Facility (City and State)	Start and End Date of License

**APPLICANT AND ADMINISTRATOR CERTIFICATION AND SIGNATURE OF AGREEMENT:**

**Note:** All sections of the application must be completely filled out and the signature of the Applicant and Administrator (if not the same person) are required in this section in order for the application to be considered complete. This section, in addition to the Alaska child care licensing statutes and regulations, should be carefully read and understood prior to signing the application.

I have read the applicable Municipality of Anchorage Code and State of Alaska child care licensing statutes and regulations: AMC 16.55, AS 47.05, AS 47.32, 7 AAC 10, and 7 AAC 57, and understand and agree to comply with them;

I will cooperate with the Anchorage Health Department (AHD) through the licensing process and after license issuance, including inspection and investigation and permit representatives of the AHD to have full access to inspect and investigate the child care facility and premises, review records, interview staff and interview individuals and their families receiving services;

I understand that I am required to maintain and retain records necessary to demonstrate compliance with the Municipality of Anchorage Code and the State of Alaska child care licensing statutes and regulations governing the facility. In addition, I will make these records available to the AHD or its authorized representatives, upon request; and

I certify that the contents of this application and information provided with it are true, accurate, and complete. I understand that willful misrepresentation of the information provided is cause for immediate denial of an application or later revocation of the license.

---

Facility Name

---

Applicant (Owner) Name (Print)

---

Date

---

Signature of Applicant

---

Administrator Name (Print)

---

Date

---

Signature of Administrator



Office Use Only

**Municipality of Anchorage  
Child Care Licensing Program**

**REQUEST FOR NIGHTTIME CARE SPECIALIZATION**

This form is required to be submitted for a child care facility seeking to offer child care services any time after 10:00 p.m. or before 6:00 a.m., or 24 hours a day. Approval of this specialization is required regardless of the duration of services provided during this time period. An approval for nighttime care will also be necessary from your local or state fire marshal's office prior to a nighttime care specialization being approved by the department.

**7 AAC 57.805. Nighttime care specialization.** (a) A child care facility may not provide care between the hours of 10:00 p.m. and 6:00 a.m. unless the facility has a nighttime care specialization approved by the department. (b) A child care center that provides nighttime care shall provide a room away from sleeping children where children who are awake may engage in activities. (c) A child care home shall provide nighttime care to no more than five children, including the caregiver's own children\* under 18 years of age.

**Facility Name:** \_\_\_\_\_

**Facility Type:**                       Home                                               Center

**Identify the hours you would like to provide nighttime care:** \_\_\_\_\_

**Maximum number of children you will have in care during nighttime care hours:** \_\_\_\_\_  
(This number must include your own children, including any foster children under 18 years of age)

**In order to be approved for a nighttime care specialization, a facility must submit their nighttime care plan and attach any supporting documentation necessary to show compliance with licensing regulations with this form. A facility's nighttime care plan must include how the facility will provide the following:**

- A shower, tub or sponge bath as needed for body cleanliness.
- Dinner, nighttime snack, and breakfast.
- Supervision for sleeping children in care.
- Accommodations for sleeping children.
- Accommodations away from sleeping children for children who are awake to engage in activities.
- Fire inspection report confirming approval for nighttime care.

\_\_\_\_\_  
**Administrator Printed Name**

\_\_\_\_\_  
**Administrator Signature**

\_\_\_\_\_  
**Date**



Office Use Only

**Municipality of Anchorage  
Child Care Licensing Program**

**REQUEST FOR SPECIALIZED PROGRAM ACTIVITY**

This form is required when a child care facility is seeking to offer a moderate-risk activity as identified in child care licensing regulations as listed below. A separate form and supporting documentation must be submitted and approved by the department for each activity your facility would like to provide.

**7 AAC 57.810 and AMC 16.55.280 Specialized program activities.** (a) A child care facility may not provide a program of moderate-risk activities on a regular basis unless the facility has approval by the department for a specialized program activity. Moderate-risk activities include specialized program activities such as gymnastics, swimming, camping, wilderness walks, horseback riding, canoeing, skiing, climbing, fishing, skateboarding, rollerblading, scooter riding, and bike riding.

*\*\*Contact your Child Care Licensing Specialist with questions regarding other possible moderate-risk activities. \*\**

**Facility Name:** \_\_\_\_\_

**Specialized Program Activity:** \_\_\_\_\_

**Facility Type:**                       **Home**                       **Center**

**Submit this form and attach a written plan with all supporting documentation necessary to show compliance with licensing regulations AMC 16.55.280. and 7 AAC 57.810. A specialized program activity plan must address how the facility will meet the following requirements:**

- Ensure each employee reviews the plan and has a copy with them during each specialized program activity.
- Ensure the plan has emergency and injury control procedures for any specialized program activity conducted, and includes:
  1. Carrying or posting emergency telephone numbers.
  2. Identification of, respect for, and avoidance of potential weather hazards.
  3. Identification and warning to children of other potential hazards.
  4. Development of contingency plans to deal with lost children, accidents, and other emergencies.
- Ensure the facility's plan for supervision during the specialized program activity includes:
  1. The required child-to-caregiver ratios are maintained or increased as appropriate to the specialized program activity.
  2. Designated caregiver(s) to supervise the specialized program activity who has at least one year experience in the specialized program activity.
  3. Designated caregiver(s) to supervise the specialized program activity who has demonstrated the necessary competency, experience, and has special training for the activity (attach any applicable certificates).
  4. Designated caregiver(s) who has received special training to protect the health, safety, and welfare of the children who have special needs.



- Ensure the facility takes the following general health and safety precautions during a specialized program activity:
1. Brings a full first aid kit.
  2. Has at least one caregiver for every 20 children with first aid & CPR to accompany children.

- Ensure the facility's plan addresses the following for boating activities:
1. List boating site and its facilities
  2. Types of boats to be used
  3. List life guards
  4. List safety equipment to be used
  5. Insurance coverage

---

Administrator Printed Name

---

Administrator Signature

---

Date



**Municipality of Anchorage  
Child Care Licensing Program**

**ADMINISTRATOR DESIGNATION AND QUALIFICATION FORM**

**Name of Administrator Applicant:** \_\_\_\_\_

**Name of Facility:** \_\_\_\_\_

This form provides the department with information about the individual who will be responsible for the day-to-day operations of the facility.

1. Read and mark the items applicable to your facility type and attach documentation to support compliance with licensing regulations. Supporting documentation includes but is not limited to, proof of:
  - **Age** – such as birth certificate, passport, or passport card, driver’s license, or state identification card;
  - **Education and/or training** – such as transcripts, certificates of completion, training or employment training attendance records;
  - **Experience in child care, financial, and managerial/supervisory** – such as a resume documenting employment history summarizing job duties performed.
2. Attach four completed *Child Care Facility Administrator Reference CC57* forms signed and dated by the person making the recommendation. At least **one** reference must be from an individual who can attest to your professional skills. **Three** of the references must be from individuals who are not related to you.
3. Submit this form and all applicable attachments to the department for approval.

**The Administrator must provide supporting documentation to demonstrate compliance with the following requirements based on their facility type:**

**An Administrator for a Child Care Home:**

Must be at least 21 years of age.

**An Administrator for a Child Care Center:**

Must be at least 21 years of age.

Must have the management and supervisory skills necessary to select and supervise personnel, including delegation of responsibility and motivation of staff.

Must have at least 12 semester hours of college credit in early childhood development, child development, child psychology, or the equivalent, or hold a current CDA credential, or Montessori Certificate.

**In addition to the above specific facility type requirements, Administrators for *all child care facility* types must provide supporting documentation showing they meet the following qualifications:**

- Are an adult with sufficient experience;
- Have early childhood training or education to fulfill the duties of an Administrator;
- Have an understanding of the development of children;
- Have the ability to care for children;
- Have the skills to work with:
  - Children;
  - Family members;
  - Department staff;
  - Community agencies; and, if applicable
  - Staff of the child care facility.
- Have the skills necessary to handle finances and plan and evaluate programs.
- Have completed the health and safety trainings required by 7 AAC 57.350(a)(4):
  - Prevention and control of infectious diseases, including immunizations;
  - Prevention of sudden infant death syndrome and use of safe sleeping practices for children of all ages;
  - Administration of medication, consistent with standards for parental consent;
  - Prevention of and response to emergencies due to food and allergic reactions;
  - Building and physical premises safety, including identification of and protection from hazards, bodies of water, and vehicular traffic Staff of the child care facility.
  - Prevention of shaken baby syndrome, abusive head trauma, and child maltreatment;
  - Emergency preparedness and response planning for emergencies resulting from a natural disaster, or a human-caused event;
  - Handling and storage of hazardous materials and the appropriate disposal of bio-contaminants;
  - Appropriate precautions in transporting children (*if applicable*);
  - Pediatric first aid and pediatric cardiopulmonary resuscitation (CPR); and
  - Recognition and reporting of child abuse and neglect under state and local law.

**I certify that the contents of this form and information provided are true, accurate and complete.**

\_\_\_\_\_  
**Printed Name of Facility Owner/Governing Body Representative**

\_\_\_\_\_  
**Signature of Facility Owner/Governing Body Representative**

\_\_\_\_\_  
**Date**

\_\_\_\_\_  
**Printed Name of Administrator**

\_\_\_\_\_  
**Signature of Administrator**

\_\_\_\_\_  
**Date**



**Municipality of Anchorage  
Child Care Licensing Program**

**CHILD CARE FACILITY - ADMINISTRATOR REFERENCE**

Administrators of licensed Child Care Homes and Centers are required to submit references from individuals who can attest to their personal and professional experience, reputable character, ability to care for children, and ability to operate a child care facility.

**Name of Administrator Applicant:** \_\_\_\_\_

**Name of Facility:** \_\_\_\_\_

**Please answer the following questions regarding the Administrator Applicant:**

1. How long have you known this individual, and in what capacity?
  
2. Please explain how this individual has worked successfully with children and families and acted as a positive role model for children.
  
3. Please explain how this individual's particular skills and abilities will support them to work successfully with children, family members, department staff, community agencies, and staff of the child care facility.
  
4. Please explain how this individual has demonstrated the characteristics of a responsible individual of reputable character, who exercises sound judgment.
  
5. Describe how you would feel about leaving a child in this individual's care.

6. Explain why you believe this individual is qualified to operate a licensed child care facility.
7. Explain this individual's administrative and supervisory skills as it would relate to their leadership position in a child care facility.

**To your knowledge, has this individual:**

8. Ever abused or neglected a child? YES  NO
9. Been charged with or convicted of a crime? YES  NO

**To your knowledge, does this individual have:**

10. A physical or behavioral health problem that poses a significant risk to children in care? YES  NO
11. A domestic violence problem that poses a significant risk to children in care? YES  NO

**If you answered YES to any of the questions 8-11, please explain.**

12. Please include any additional comments and/or information you would like to share:

You may also contact the Child Care Licensing program at 907-343-4758 with any questions or concerns. A Child Care Licensing Specialist may follow up with you regarding this reference.

Thank you for your assistance.

---

**Printed Name of Individual Providing Reference**

---

**Phone Number**

---

**Signature of Individual Providing Reference**

---

**Date**



Office Use Only

Municipality of Anchorage
Child Care Licensing Program

CHILD CARE FACILITY PERSONNEL POLICIES CHECKLIST

Facility Name: \_\_\_\_\_

This form provides the department with information about the facility’s personnel policies. Please complete this form by checking off each item and indicate the page number where the information is located and submit this form and all applicable attachments to the Child Care Licensing (CCL) Program for approval.

Child care licensing regulations define a “caregiver” as an administrator, child care associate, employee, student intern, regular parent classroom volunteer, substitute or any other individual in a child care facility whose duties include supervision of children with or without compensation.

REQUIRED:

AMC 16.55.110A., B. and 7AAC 57.220 (a) (1-3). A child care facility with one or more employees shall provide personnel policies to those employees when they start employment at the facility. The personnel policies must include as applicable:

- 1. Personnel qualifications for each position title. Page(s): \_\_\_\_\_
[ ] Age requirement.
[ ] Desired and minimum education requirement.
[ ] Desired and minimum experience requirement.
[ ] Required references.
2. Job description for each position title. Page(s): \_\_\_\_\_
[ ] Title of position
[ ] Person to whom employee is responsible to and/or for
[ ] General position description and duties
[ ] Daily routines
[ ] Periodic and occasional duties
[ ] Weekly work schedule (hours and days)
3. Evaluation procedures. Page(s): \_\_\_\_\_
[ ] Procedures for annual evaluations
[ ] Copy of blank evaluation form being used
4. [ ] Equal opportunity statement. Page(s): \_\_\_\_\_
5. [ ] Termination policy. Page(s): \_\_\_\_\_
6. [ ] Training plan. Page(s): \_\_\_\_\_

RECOMMENDED:

The following are areas recommended to be included in your personnel policies to reflect managerial best practices regarding communication and expectations of employees.

- [ ] Statement of employer vision, mission, and goals. Page # \_\_\_\_\_
[ ] Organization Chart. Page # \_\_\_\_\_
[ ] Statement of Governing Body/Board Members and role (if applicable). Page # \_\_\_\_\_

**Basic Terms of Employment:**

- Hours of workday and workweek. *Page #* \_\_\_\_\_
- Overtime. *Page #* \_\_\_\_\_
- How time worked is documented. *Page #* \_\_\_\_\_
- When salaries are paid. *Page #* \_\_\_\_\_

**Salaries and Benefits:**

- Salary Range. *Page #* \_\_\_\_\_
- How increases are determined. *Page #* \_\_\_\_\_
- Benefits provided (as required by Department of Labor: unemployment, work comp, etc.) *Page #* \_\_\_\_\_
- Optional benefits provided (paid time off, child care discount, insurance, etc.) *Page #* \_\_\_\_\_

**Attendance and Leave Policies:**

- Attendance expectation. *Page #* \_\_\_\_\_
- Policies on tardiness and absences. *Page #* \_\_\_\_\_
- Vacation/Sick Leave. *Page #* \_\_\_\_\_
- Leave specific to other circumstances (jury duty, funerals, voting, maternity and etc.). *Page #* \_\_\_\_\_

**Training Expectations and Requirements:**

- Orientation and training requirements. *Page #* \_\_\_\_\_
- Annual training requirements for Administrator. *Page #* \_\_\_\_\_
- Annual training requirements for Child Care Associate. *Page #* \_\_\_\_\_
- Annual training requirements for caregivers. *Page #* \_\_\_\_\_
- CPR and First Aid requirements. *Page #* \_\_\_\_\_

**Disciplinary Actions and Grievance Procedures:**

- Reasons for disciplinary action and process. *Page #* \_\_\_\_\_
- Reason for dismissal. *Page #* \_\_\_\_\_
- Grievance process. *Page #* \_\_\_\_\_
- Appeal process. *Page #* \_\_\_\_\_

**Other:**

- Smoking policy and areas. *Page #* \_\_\_\_\_
- Parking policy and areas. *Page #* \_\_\_\_\_
- Use of facility telephone and personal cell phone use. *Page #* \_\_\_\_\_
- Policy about staff's own children at facility (if applicable). *Page #* \_\_\_\_\_
- Requirements and recommendations about appropriate clothing and language. *Page #* \_\_\_\_\_

**Facility Best Practice:**

- Supervision of children. *Page #* \_\_\_\_\_
- Child-to-caregiver ratios. *Page #* \_\_\_\_\_
- Maximum group size. *Page #* \_\_\_\_\_
- Caregiver behavior and attitudes toward children. *Page #* \_\_\_\_\_
- Behavior guidance. *Page #* \_\_\_\_\_
- Reporting abuse and neglect. *Page #* \_\_\_\_\_
- Medication – stored and administered as required by 7 AAC 10.1070. *Page #* \_\_\_\_\_
- Reducing the spread of disease. *Page #* \_\_\_\_\_
- Transportation rules (during emergencies or regular transporting). *Page #* \_\_\_\_\_
- Nutrition and infant feeding. *Page #* \_\_\_\_\_
- Equipment and supplies. *Page #* \_\_\_\_\_
- Children with special needs. *Page #* \_\_\_\_\_
- Diapering Procedures. *Page #* \_\_\_\_\_



## Municipality of Anchorage Child Care Licensing Program



### PARENTS' GUIDE TO LICENSED CHILD CARE

This form is required to be included in a child care facility's policy and must be provided to parents at enrollment.

◆ **Choosing care for your child is a significant decision.**

When you entrust the care of your child to another person, you are making an important decision. Visit, ask questions, and carefully compare several programs. Licensed care includes child care homes and centers. Your choice depends on what you want and need for your child.

◆ **Licensing is a key to quality child care.**

Licensing promotes good care by setting basic health and safety standards. Before a home or center is granted a child care license, it must meet minimum regulatory standards such as: health, safety, and program requirements. Child Care Licensing Specialists from the Child Care Licensing Program conducts on-site inspections at a facility to monitor regulatory compliance and to investigate reports of concern. The goal of licensing is to prevent predictable risks of harm to children; however, licensing cannot guarantee that a facility meets all requirements at all times.

◆ **An informed parent is a key to quality child care.**

Parents are responsible for choosing and monitoring their child's care. Licensors generally visit a minimum of twice a year, but you visit each time you take your child. Visit unexpectedly sometimes or in the middle of the day. Keep an eye on the quality of care. What do you see when you visit? Is the environment safe? Are caregivers knowledgeable, nurturing, and communicating with you about your child's daily care and needs? How many children are present, are there enough caregivers? Are activities appropriate? Watch how your child responds to the program and interacts with caregivers. Listen to what your child says and pay attention to changes in their behavior. It's ultimately a parent's decision to choose a facility which meets their family's needs and their standards for health, safety, and quality.

◆ **What to do if you have questions or concerns about the care your child is receiving:**

First discuss with your caregiver or the facility's Administrator or Child Care Associate if you have any concerns, observe any health or safety issues, or feel the facility's program needs improvement. If you are still concerned, believe children may be in danger, or feel a licensing standard has been violated, **contact the Child Care Licensing Program at 907-343-4758** or via email at [HHSCCL@muni.org](mailto:HHSCCL@muni.org).

### CHILD-TO-CAREGIVER RATIO REQUIREMENTS FOR LICENSED CHILD CARE FACILITIES

#### CHILD CARE HOMES

- 1 caregiver required; must be at least 21 years of age
- No more than 5 children younger than 13 years of age, including the caregiver's own children, without fire safety approval
- No more than 8 children younger than 13 years of age, including the caregiver's own children, with fire safety approval
- No more than 3 children under the age of 30 months
- No more than 2 children may be non-ambulatory
- No more than 5 children, including the caregiver's own children under the age of 18 years, are allowed in nighttime care between the hours of 10:00 p.m. and 6:00 a.m., with fire safety approval

#### CHILD CARE CENTERS

- Administrator and/or Child Care Associates must be at least 21 years of age
- 9 or more children in care, with fire safety approval

The number of caregivers, who are at least 18 years of age, need to meet child-to-caregiver ratios:

- 1 caregiver for every 4 young infants (birth through 11 months)
- 1 caregiver for every 5 older infants (12 months through 18 months)
- 1 caregiver for every 6 toddlers (19 months through 35 months)
- 1 caregiver for every 10 preschool children (3- to 4-year-olds)
- 1 caregiver for every 10 kindergarten children (5- to 6-year-olds)
- 1 caregiver for every 10 school age children (7 through 12-year-olds)

See AMC 16.55.170 for allowable maximum group sizes in a center



## **CHILD CARE FACILITIES MUST MEET THE FOLLOWING REQUIREMENTS TO BE LICENSED**

### **TO BE LICENSED**

- Required to apply for a Provisional or Biennial License
- Must meet all licensing standards and requirements
- Must be in compliance with all licensing regulations
- Must allow the Child Care Licensing (CCL) program access to inspect the facility and premises to ensure licensing compliance and to investigate complaints
- All staff/household members must have valid criminal history check from the State of Alaska Background Check Program
- All caregivers must meet the licensing early child development training requirements

### **OBTAIN FROM PARENTS**

- Child's immunization records or an approved exemption form
- Child emergency information
  - must be updated by parent when changes occur or at least semi-annually
- Permission for:
  - medication administration
  - transportation
  - field trip participation
- A plan of care for a child identified with a special need
- A behavior guidance plan for a child with a behavior issue

### **PROGRAM REQUIREMENTS**

- Must promote children's healthy development
- Must include quiet and active, group and individual, indoor and outdoor activities
- Must include minimum of 20 minutes of vigorous physical activity for every 3 hours in care
- Must prohibit screen time viewing including T.V., computers and hand-held devices for children under two years of age
- Must ensure screen time viewing for children two years and over is limited to 1 hour in a 24-hour period except for special occasions
- Must have a specialization approved by CCL to provide nighttime care or allow children to participate in a moderate risk activity

### **SUPERVISION**

- Ensure children are always supervised by an adult caregiver
- Ensure children receive age-appropriate supervision
- Ensure a child's whereabouts are known at all times while in care
- Ensure child-to-caregiver ratios are always met

### **SAFETY**

- Must meet CCL and fire safety standards
- Must have an emergency evacuation plan, train staff, and document monthly evacuation drills
- Ensure water temperature is between 100- and 120-degrees Fahrenheit
- Ensure firearms and ammunition are stored properly away from children. Note: firearms and ammunition are prohibited in a child care center
- Ensure the facility is free of hazards inside and outside
- Ensure electric outlets accessible to children under age 5, have child protective outlet covers

### **BEHAVIOR GUIDANCE**

- Must be positive and never cruel, humiliating, or damaging to the child
- Must set realistic expectations and clear and consistent limits
- Must not be disciplined or punished related to eating, napping, or toileting
- Ensure if time-outs are used, they are age appropriate, and a child is never removed from other children for more than 10 minutes
- Ensure corporal punishment of children is prohibited. Note: corporal punishment means "the infliction of bodily pain as a penalty for a disapproved behavior. It includes shaking, spanking, delivering a blow with a part of the body or an object, slapping, punching, pulling or any other action that seeks to induce pain.

**HEALTH**

- Ensure the facility meets cleaning and sanitation standards
- Ensure meals and snacks are nutritious and follow Alaska Food Program standards
- Ensure sanitary practices are used for food preparation and handling
- Must notify parents if their child is exposed to a contagious or communicable disease
- Ensure a medical provider approves attendance before admitting a seriously ill child
- Ensure drinking water is safe
- Ensure facility is smoke free
- Ensure there is always a caregiver with CPR and first aid certification present
- Ensure medicine and toxic materials are labeled and stored safely out of reach
- Ensure medicine is only administered with parent permission
- Ensure a caregiver's own child and all children in care are treated equitably

**EQUIPMENT AND SUPPLIES**

- Ensure furniture and equipment are safe and durable
- Ensure there is an adequate and varied amount of age-appropriate toys and books available for children in care
- Ensure children have storage space for their belongings
- Ensure children under age 5 have a cot/mat/bed and bedding that is clean and sanitary for resting
- Ensure infants sleep on their backs in an approved crib free from materials and blankets that could increase the risk of suffocation

**SPACE**

- Must have indoor and outdoor space to accommodate the physical and developmental needs of children in care:
  - 35 square feet of usable indoor space per child
  - 75 square feet of usable outdoor space per child



Municipality of Anchorage  
Child Care Licensing Program

Get Out Alive!

Disaster Preparedness and Emergency Evacuation Plan

Office Use Only

A licensed child care facility must have a disaster preparedness and emergency evacuation plan that includes evacuation procedures that will ensure the complete evacuation of children in care, including children with limited mobility, within 150 seconds (2 ½ minutes). For further information, refer to 7AAC 10.1010 (Licensed Providers). This form is provided for your convenience to document your facility's Disaster Preparedness and Emergency Evacuation Plan or to use as a guideline for developing your own plan. All of the requirements listed in this guideline are required as part of your Disaster Preparedness and Emergency Evacuation Plan.

**The Disaster Preparedness and Emergency Evacuation Plan requires both a floor plan mapping your child care facility's evacuation routes and a written plan describing the procedures to be followed.**

**The floor plan must include identification of:**

- Smoke detectors, fire extinguishers, and carbon monoxide detectors;
- Escape routes from every room with doors and windows clearly marked for each level of the child care facility; and
- Specified meeting place outside the facility.

**The written plan must describe detailed procedures the child care facility will follow, including:**

- How the facility will ensure evacuation of everyone within 150 seconds, including children under 30 months of age, children with limited mobility, and children who otherwise may need assistance in an emergency, including a child who is mentally, visually, or hearing impaired;
- What the facility will do during emergency situations or natural disasters that may affect the facility, including, as appropriate:, fire, tsunami/ flooding, earthquake emergencies, lock-down, shelter in place and etc.;
- The relocation site and plan to reunify children with their parents in the event of the need to relocate due to an evacuation;
- How the facility will conduct and record monthly emergency evacuation drills and ensure participation of all employees who are on duty during the scheduled drill;
- The location of disaster and first aid kit(s); and
- Training of staff on the implementation of the Disaster Preparedness and Emergency Evacuation Plan.

Sample Floor Plan Evacuation routes (each floor of child care facility must be drawn separately)

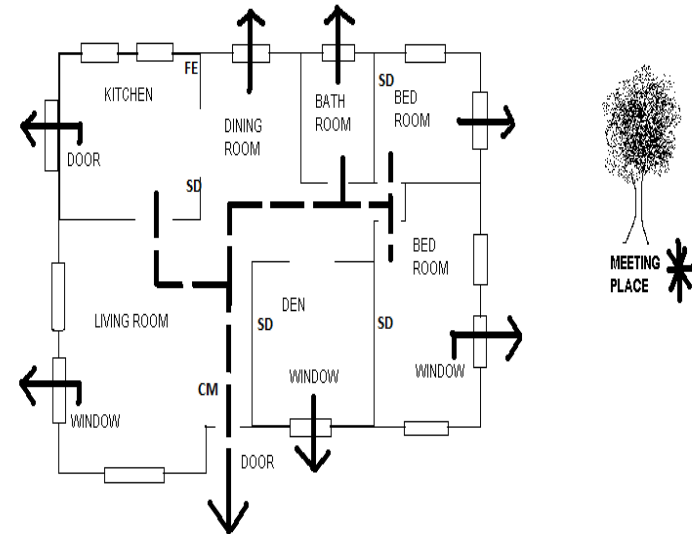

FE = Fire Extinguisher  
SD = Smoke Detector  
CM = Carbon Monoxide Detector

Facility Name: \_\_\_\_\_ Physical Address: \_\_\_\_\_

Facility Floor Plan:

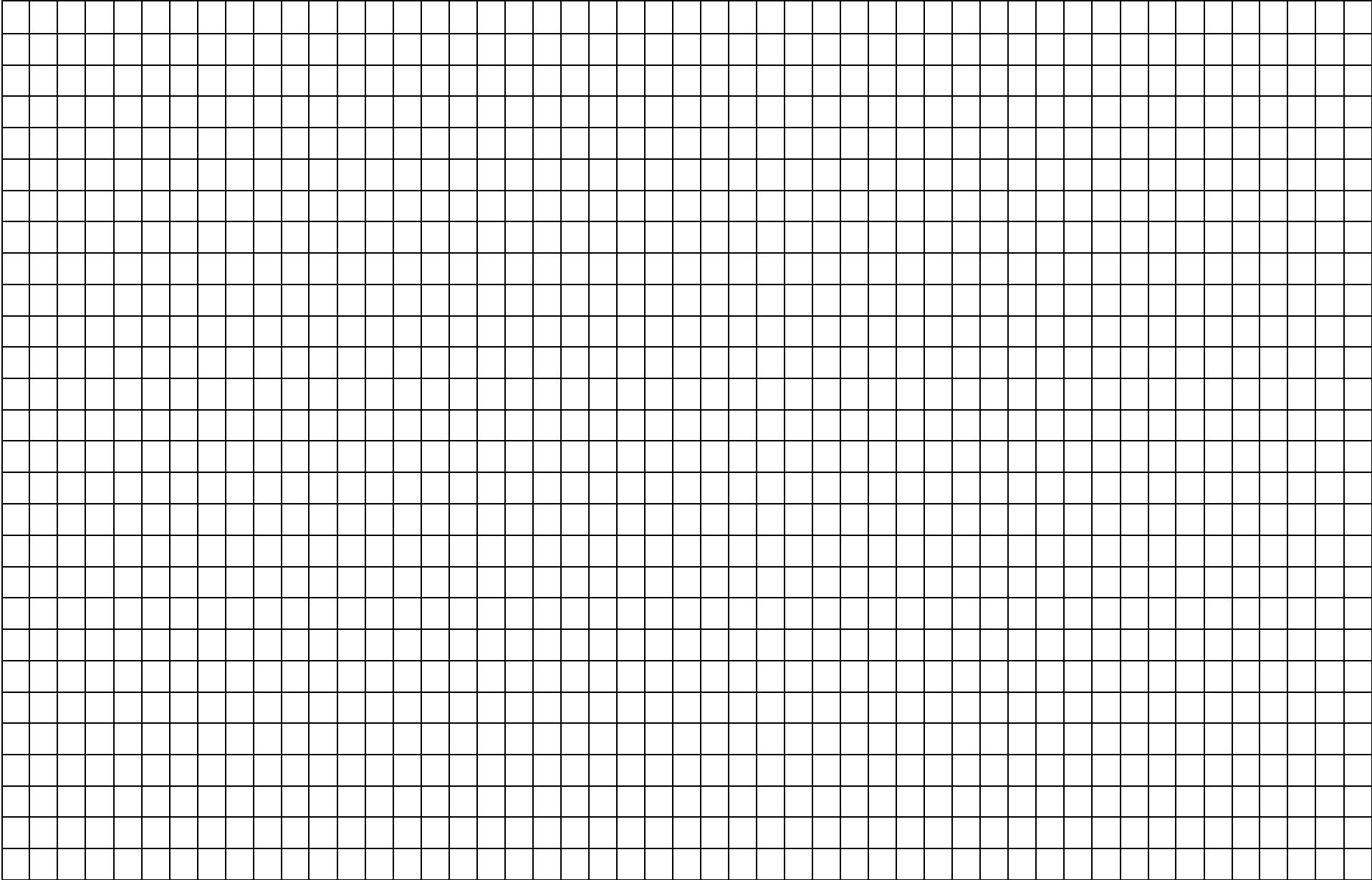

Facility Name: \_\_\_\_\_

Physical Address: \_\_\_\_\_

Facility Written Plan:

---

---

---

---

---

---

---

---

---

---

---

---

---

---

---

---

---

---

---

---

---

---

---

---

Facility Name: \_\_\_\_\_ Physical Address: \_\_\_\_\_

Facility Written Plan:

---

---

---

---

---

---

---

---

---

---

---

---

---

---

---

---

---

---

---

---

---

---

---

---



Municipality of Anchorage  
Child Care Licensing Program

Office Use Only

**CHILD CARE FACILITY STAFFING PLAN**

Facility: \_\_\_\_\_ Room: \_\_\_\_\_  
 Month/Year: \_\_\_\_\_ Age Range: \_\_\_\_\_  
 Hours of Operation: \_\_\_\_\_ Number of Children: \_\_\_\_\_  
 Day(s) of Week: \_\_\_\_\_

Position	Caregiver Name					Number of Children	Number of Staff	Required Ratio
	<i>Example Staff</i>							
<b>CCA</b>								
<b>CPR/FA</b>								
6:00 am								
6:30 am								
7:00 am	<b>7:15</b>							
7:30 am	<b>X</b>							
8:00 am	<b>X</b>							
8:30 am	<b>X</b>							
9:00 am	<b>X</b>							
9:30 am	<b>X</b>							
10:00 am	<b>X</b>							
10:30 am	<b>X</b>							
11:00 am	<b>X</b>							
11:30 am	<b>11:30</b>							
12:00 pm	<b>12:15</b>							
12:30 pm	<b>X</b>							
1:00 pm	<b>X</b>							
1:30 pm	<b>X</b>							
2:00 pm	<b>X</b>							
2:30 pm	<b>X</b>							
3:00 pm	<b>X</b>							
3:30 pm	<b>X</b>							
4:00 pm	<b>4:00</b>							
4:30 pm								
5:00 pm								
5:30 pm								
6:00 pm								
6:30 pm								
7:00 pm								
7:30 pm								
8:00 pm								
8:30 pm								
9:00 pm								
9:30 pm								
10:00 pm								

Note: if providing nighttime care between the hours of 10:00 pm to 6:00 am complete page 2.

# Child Care Facility Staffing Plan

(Use a separate form for each room or age group)

Facility: \_\_\_\_\_ Room: \_\_\_\_\_  
 Month/Year: \_\_\_\_\_ Age Range: \_\_\_\_\_  
 Hours of Operation: \_\_\_\_\_ Number of Children: \_\_\_\_\_  
 Day(s) of Week: \_\_\_\_\_

Caregiver Name and Position						Number of Children	Number of Staff	Required Ratio
Example Staff								
<b>Position</b>	<i>CCA</i>							
<b>CPR/FA</b>								
10:00 pm								
10:30 pm	<i>10:30</i>							
11:00 pm	<i>X</i>							
11:30 pm	<i>X</i>							
12:00 am	<i>X</i>							
12:30 am	<i>X</i>							
1:00 am	<i>X</i>							
1:30 am	<i>1:45</i>							
2:00 am	<i>2:15</i>							
2:30 am	<i>X</i>							
3:00 am	<i>X</i>							
3:30 am	<i>X</i>							
4:00 am	<i>X</i>							
4:30 am	<i>X</i>							
5:00 am	<i>X</i>							
5:30 am	<i>X</i>							
6:00 am	<i>6:00</i>							

**General Instructions for Completion:**

- For each staff member providing direct care enter the following information in their appropriate boxes:
  - Name (first and last), if the individual is a current staff member and this information is known.
  - Position: Use the following: ADMIN for Administrator, CCA for Child Care Associate, CG for Caregiver
  - Pediatric CPR/FA by using a check mark to indicate the staff has valid certification(s)
  
- Indicate the time each staff begins providing direct care to children by entering their start time in the box. (For example: provides care at 7:15am enter in the 7:00am box “7:15”). Enter an “x” in each box indicating the times they are providing direct care. Indicate the time the staff stops providing direct care by entering in their end time in the box. (For example: stops providing care at 4:00pm enter in the 4:00pm box “4:00”).
  
- New facilities complete form(s) as if operating at capacity.
  
- Staff to child ratios must be maintained at all times.

**Licensed Home**

1:8 Staff/Child Ratio  
 No more than 3 children under 30 mos.  
 No more than 2 non-ambulatory

**Licensed Center**

Ages of Children	Staff/Child Ratio
Young infants 6 wks. through 11 mos.	1:4
Older infants 12 mos. through 18 mos.	1:5
Toddlers 19 mos. through 36 mos.	1:6
Preschool - 3 yrs. through 4 yrs.	1:10
Kindergarten - 5 yrs. through 6 yrs.	1:10
School Age - 7 yrs. through 12 yrs.	1:10





Office Use Only

Municipality of Anchorage
Child Care Licensing Program

PERMISSION TO OPERATE A CHILD CARE BUSINESS

An Applicant who applies for a Child Care License through the Municipality of Anchorage Child Care Licensing Program must meet all applicable requirements, including but not limited to the following:

- 1. The applicant must submit evidence of the property owner's permission to operate a child care business prior to receiving a license. This form completed and signed by the property owner/property manager must be submitted by the applicant to licensing as part of the application packet.
2. The entity and premises must meet all of the regulatory and safety requirements. An inspection by licensing will be conducted to determine the facility meets all health and safety requirements.
3. The entity must comply with local and state fire requirements, as applicable to facility type. An inspection or plan review by the local Fire Marshall will be conducted if the application is for six or more children to ensure the facility meets all applicable fire code requirements.
4. The entity must comply with Department of Conservation (DEC) requirements for water supply and/or wastewater and food preparation. An application to be licensed as a child care center requires an inspection by DEC. Applications to be licensed as a home may require an inspection by DEC for water supply and/or wastewater disposal.
5. The entity must maintain comprehensive general liability insurance, including transportation coverage, if applicable, at all times.

This form must be filled out by the property owner or manager notifying the program of whether or not the applicant has your permission to operate a licensed child care business in the building you own. If you have questions or concerns to report, please contact the Child Care Licensing Program at (907) 343-4758. Please keep a copy for your records.

Name of Applicant: \_\_\_\_\_

Physical Address of Facility: \_\_\_\_\_

Name of Property Owner/Property Manager: \_\_\_\_\_

Mailing Address of Property Owner/Property Manager: \_\_\_\_\_

Daytime telephone number of Property Owner/Property Manager: \_\_\_\_\_

[ ] Property Owner [ ] Property Manager

[ ] I give my permission for my tenant to operate a licensed child care business at the aforementioned property. I attest that the covenants, homeowner's association bylaws, and other applicable neighborhood restrictions do not forbid operating a child care business at this address.

[ ] I do not give my permission for my tenant to operate a licensed child care business at the aforementioned property.

Printed Name of Property Owner / Property Manager

Date

Signature of Property Owner/Property Manager



**Municipality of Anchorage  
Child Care Licensing Program**

Office Use Only

**PLAN FOR ALTERNATE OUTDOOR RECREATION SPACE**

All child care facilities are required to have outdoor space to accommodate the physical and developmental needs of children in care. Child facilities must provide at least 75 square feet of useable outdoor recreation space per child for the maximum number of children outside at any one time.

AMC 16.55.260A. A child care home shall meet the same indoor and outdoor space requirements as set out in 7 AAC 57.620(b). AMC 16.55.260B. Except as provided in this section, in a center the playground shall adjoin the building and shall be accessible safely by all children.

For homes: If adequate space is not available, parks or other outdoor locations that are easily accessible may be used. Approval from the department is required if alternate outdoor space is used. Use this form to describe the facility's plan for alternative outdoor recreation space.

1. Area(s) to be used (description or diagram of area to be used and equipment available):
  
  
  
  
  
  
  
  
  
  
2. What is the age range of the children who will use this space?
  
  
  
  
  
  
  
  
  
  
3. What toilet facilities are available?
  
  
  
  
  
  
  
  
  
  
4. Proposed time schedule (list times of day and days of week)

5. Transportation method and safety plans: (First aid kit, emergency record cards, and cell phone, etc.)

---

Printed Name of Administrator

---

Signature of Administrator

---

Date

---

Facility Name



Municipality of Anchorage  
Child Care Licensing Program

**CHILD CARE FACILITY PARENT POLICIES CHECKLIST**

**Facility Name:** \_\_\_\_\_

This form provides child care licensing with information about the facility’s parent policies. Please complete this form by checking off each item and indicate the page number where the information is located and submit this form and all applicable attachments to the MOA Child Care Licensing (CCL) Program office for approval.

**REQUIRED:**

**AMC 16.55.160 and 7 AAC 57.410.** At or before a child’s admission, a child care facility shall supply a parent with the following information in writing:

- Enrollment requirements and procedures. *Page#*\_\_\_\_\_
- Fees and payment requirements. *Page#*\_\_\_\_\_
- Hours and days of operation, including holidays. *Page#*\_\_\_\_\_
- Summary plan for supervision of children (required for all facility types under 7 AAC 57.500 but must be in writing for centers per 7 AAC 57.410). *Page#*\_\_\_\_\_
- Number and ages of children served. *Page#*\_\_\_\_\_
- Policies and provisions for ill children, including parent permission for medication, as applicable. *Page#*\_\_\_\_\_
- Typical daily schedule of activities for each age group of children in care (7 AAC 57.520). *Page#*\_\_\_\_\_
- Screen viewing time, including TV, movie viewing, computers, video games, and hand-held devices (in compliance with AMC 16.55.190C. through E). *Page#*\_\_\_\_\_
- Behavior guidance practices (in compliance with AMC 16.55.200 and 7 AAC 57.535). *Page#*\_\_\_\_\_
- Cold weather outdoor play policy (following local school district outdoor recess policies is recommended). *Page#*\_\_\_\_\_
- List of examples of meals and snacks served [in compliance with AMC 16.55.220A.2. and 7 AAC 57.560(a)]. *Page#*\_\_\_\_\_
- Parent permission policy for activities away from the facility. *Page#*\_\_\_\_\_
- Transportation arrangements, if any [in compliance with AMC 16.55.230B. through E. and 7 AAC 57.565(d)]. *Page#*\_\_\_\_\_
- Parental access and visiting policy [in compliance with 7 AAC 57. 520(e)]. *Page#*\_\_\_\_\_
- Use of substitute, emergency, and volunteer caregivers. *Page#*\_\_\_\_\_
- Animals present in the facility, if applicable and submit ***Animals on Child Care Facility Premises CC105.*** [in compliance with 7 AAC 10.1090(b)]. *Page#*\_\_\_\_\_
- Firearms in the facility, if applicable and submit ***Firearms and Ammunition Storage CC103.*** [in compliance with 7 AAC 10.1080(c)]. *Page#*\_\_\_\_\_
- Poisonous plants in the facility, if applicable and submit ***Plant Safety Plan CC93.*** [in compliance with 7 AAC 10.1095 (b)]. *Page#*\_\_\_\_\_

- Nondiscrimination policy as required by state law and AMC 5.20 (AMC 16.55.160A.1).  
*Page#*\_\_\_\_\_
- Information provided by the Department about; the parent's role to help ensure a reasonably safe and developmentally appropriate environment; about the complaint investigation role of the Department; and contact information for the Department. This is satisfied by the facility providing the parent with a copy of the ***Parents' Guide to Licensed Child Care CC61***.  
*Page#*\_\_\_\_\_
- Suspension and expulsion policy in compliance with behavior guidance practices in 7 AAC 57.535. *Page#*\_\_\_\_\_
- Policy for notifying parents about any changes to the information in the policies above.  
*Page#*\_\_\_\_\_

**Note:** Additional parent policies can be added at the discretion of the facility, such as: facility closures, termination of care notification requirements, etc.



Municipality of Anchorage  
Child Care Licensing Program

PLANT SAFETY PLAN

Office Use Only

Approval must be obtained for poisonous plants to be inside or outside the facility in areas accessible to children. This form can be used, or you can submit your own written plan for the protection of children from poisonous plants to the Child Care Licensing Program for approval.

Name of Facility: \_\_\_\_\_

Administrator: \_\_\_\_\_

Address: \_\_\_\_\_

<b>I am requesting the following poisonous or questionable plants to be in my home/center or on the premises (e.g. philodendron)</b>	<b>Specific location of each plant desired (e.g. master bedroom; fireplace mantel; kitchen shelf; west side of play yard)</b>	<b>How I will protect the children from this plant (e.g., access to the chokecherry tree and its droppings will be fenced off)</b>

(Attach additional forms if needed.)

This information I listed is based on my knowledge and/or research of common plants. I understand that if I add plants, I must complete a new form.

\_\_\_\_\_  
Administrator's Signature

\_\_\_\_\_  
Date



Municipality of Anchorage  
Child Care Licensing Program

Office Use Only

FIREARM AND AMMUNITION STORAGE

An applicant who applies for a Child Care Home license must inform licensing and all parents of children in care of the presence of firearms in the facility. Additionally, the administrator of the facility must ensure any firearms are unloaded and stored in a locked gun safe or other locked place and ammunition is stored separately from the firearms, in a place inaccessible to children in care. (7 AAC 10.1080).

Name of Administrator: \_\_\_\_\_ Date: \_\_\_\_\_

Name of Facility: \_\_\_\_\_

Physical Address of Facility: \_\_\_\_\_

I do not have firearms and/or ammunition in my child care facility or on the property. If at some point a firearm or ammunition is acquired, I will immediately contact my licensing specialist to submit the information requested below.

I have firearms and/or ammunition in my child care facility or on the property. I understand I have to comply with all applicable licensing requirements governing firearms and ammunition. The information below describes how I meet these requirements:

1. Firearms are not visible to children. They are inaccessible to children and are unloaded and stored in a:  
 locked gun safe located \_\_\_\_\_ or  
 other locked place, \_\_\_\_\_

2. The locking method used: \_\_\_\_\_

3. Ammunition is stored separately from firearms in a place inaccessible to children. Ammunition is stored: \_\_\_\_\_

4. The key or combination for the gun safe or locked place is inaccessible to children. The keys/combinations are stored: \_\_\_\_\_

\_\_\_\_\_  
Administrator's Name

\_\_\_\_\_  
Date

\_\_\_\_\_  
Administrator's Signature



Municipality of Anchorage  
Child Care Licensing Program

Office Use Only

ANIMAL ON CHILD CARE FACILITY PREMISES

An applicant who applies for a child care facility license must inform licensing and all parents of children in care of the presence of an animal or animals in the facility. Additionally, the administrator of the facility must ensure and be able to provide proof of regulatory compliance for any animal present in the child care facility. Animal(s) must be free of communicable disease, internal and external parasites, and have the immunizations required under state and federal law. (7 AAC 10.1090)

Administrator Name: \_\_\_\_\_ Date: \_\_\_\_\_

Name of Facility: \_\_\_\_\_

Physical Address of Facility: \_\_\_\_\_

I do not have animals in my child care facility or on the premises. If at some point an animal is acquired, I will immediately contact my licensing specialist and submit the information requested below.

I have animal(s) in my child care facility or on the premises. List animals on the premises, including type and breed of animal(s), and their name(s):

\_\_\_\_\_  
\_\_\_\_\_

I understand I have to comply with all applicable licensing requirements governing animals. I attest to the information below to meet these requirements:

- I have ensured that any and all animal(s) on the premises have received immunizations as required by state and federal law; have no communicable diseases, and are free of internal and external parasites; and can provide proof of compliance with the requirements for animals listed above upon request from the Child Care Licensing Program: Yes  No
- I have ensured the area around a cage or aquarium is smooth, nonabsorbent, impervious to water, easily cleanable, and will ensure it is cleaned and sanitized with the frequency necessary to keep the area clean and sanitized: Yes  No
- I will ensure the animal waste is removed daily or at a frequency necessary to prevent a health risk to the children in care, and will ensure that cleaning of animal waste is done when children in care are not present or conducted in an area used for food preparation: Yes  No
- I have informed parents of all children in care, of any animal presence on the premises: Yes  No

\_\_\_\_\_  
Administrator's Name

\_\_\_\_\_  
Date

\_\_\_\_\_  
Administrator's Signature